



LUNA 3

User's Manual



© RuggON Corporation. All rights reserved. TRADEMARKS

RuggON logo is a trademark of RuggON Corporation, registered in the United States Patent and Trademark Office and in other countries. Microsoft and the Windows logo are either registered trademarks or trademarks of Microsoft Corporation in the United States and/or other countries. Microsoft products are licensed to OEMs by Microsoft Licensing, Inc., a wholly owned subsidiary of Microsoft Corporation. The Bluetooth® word mark and logos are registered trademarks owned by Bluetooth SIG, Inc. All other brand and product names are trademarks or registered trademarks of their respective owners.

Images shown in this document may vary slightly from actual products at time of shipping. Information in this manual is subject to change without notice.

Table of Contents

About This Manual

Related Information	1
Conventions	1

Basic Safety Guidelines

Intended Use.....	2
Maintenance and Operation Overview	2
Safety.....	3
Electrical Hazards	3
Environmental	3
Radio Transmissions.....	4
Cleaning and Servicing	4
Regulatory and Certification	4
Lithium Battery Safety Statement	8
ENERGY STAR.....	10

Chapter 1. Introduction

About This Guide	11
Unpacking the Device	11
Parts List.....	12
Identifying the Device	13
Identifying the Digitizer	17
Touch Screen Features	18

Chapter 2. Getting Started

First Time Use	19
Charging the Battery	19
Powering the Device On and Off	20
Using the Digitizer	21
Installing the Pen Holder	21

Chapter 3. Operation

Connecting to External Cabling	22
Installing SIM Card.....	22

Installing the Standard Battery	23
Removing the Standard Battery	24
Checking Battery Status.....	25
Connecting to a Wireless Network.....	26

Chapter 4. Using BIOS Setup Utility

When to Use the BIOS Setup Utility	27
Accessing the BIOS Setup Utility.....	27
BIOS Passwords	29
EC/ PD and BIOS.....	31

Chapter 5. Using the DashON Utility

Overview	38
----------------	----

Chapter 6. Troubleshooting

Troubleshoot the Wi-Fi Connection	40
Troubleshoot Operating the Computer	41
Call Product Support	41

Chapter 7. Maintenance

Cleaning the Device	42
Returning the Device.....	42
Contacting RuggON	42

About This Manual

The LUNA 3 User's Manual provides instructions for qualified personnel to follow when setting up a new LUNA 3 device.

This document is intended for use by qualified personnel to compliment the training and expertise, not to replace it.

Related Information

Current information and manuals are available for download at the following website:

<https://www.ruggon.com>

Conventions

Bolded or underlined text is used to emphasize the designated information.



A Note is used to provide additional information for the device or settings.



A Caution is used to warn against potential hazards or to caution against unsafe practices.



A Warning is used to identify immediate hazards for property damage, injury or death.

Basic Safety Guidelines

The following safety guidelines are intended to help protect the user from injury and prevent damage to the hardware.

- Do not place anything on the AC adapters power cable and make sure the cable is not located where it can be tripped over or stepped on.
- Do not cover the AC adaptor as it reduces the cooling.
- Do not use the AC adapter while it is inside the carrying case.
- Use only the AC adapter and batteries that are approved for use with the device. Use of another type of battery or AC adapter may cause risk of fire or explosion.
- If you use an extension cable with the AC adapter, ensure that the total ampere rating of all products plugged in to the extension cable does not exceed the ampere rating of the extension cable.
- If the device is moved between environments with very different temperature and/ or humidity ranges, condensation may form on or within the device. Avoid damaging the device by allowing sufficient time for the moisture to evaporate before using the device.

When disconnecting cables, pull on the connector or on its strain relief loop, not on the cable itself. When pulling out or plugging in the connector, keep it evenly aligned to prevent bending the connector pins.

- Make sure the temperature for adapter will not be higher than 40°C.

Intended Use

The LUNA 3 rugged tablet is equipped with multi-functional terminals for stationary and mobile applications in industrial environments such as unmanned, law enforcement, warehousing, fleet management and manufacturing.

Read the safety guidelines thoroughly before starting any servicing on the device. Read the guidelines before powering up the device and keep this document for later use.

The operator is solely responsible for any damage resulting from unauthorized modifications to the device.

Unintended Application Use

The device is not designed for use in life-support systems or critical safety/security systems where system malfunction can lead to the direct or indirect endangerment of human life. The operator is fully responsible for using the device in these situations.

Maintenance and Operation Overview

The LUNA 3 is designed and manufactured according to strict controls and following the stated safety regulations. The following list identifies incorrect operating uses of the LUNA 3. Incorrect use of the LUNA 3 can lead to hardware damage, safety issues and possible risk to personnel health:

- The LUNA 3 is under operation by untrained personnel.
- The LUNA 3 is not maintained as recommended.
- The LUNA 3 is not used as intended.

Safety

To prevent injury and damage, read the following safety guidelines prior to operating the device. The manufacturer assumes no liability for any and all damages arising from misuse or noncompliance with these guidelines.

Electrical Hazards

Cleaning/Service: Power Off the LUNA 3

- Disconnect the LUNA 3 from power before cleaning or servicing it.

Power Adapter

Contact an authorized service personnel for repairs to the power pack. In the event of a blown fuse after replacing the fuse, contact an authorized service personnel to avoid electrical shock.

Supplied Power Cables (optional)

Use supplied power cables from RuggON.

If other power cables are used, the following may apply:

- The operator is solely responsible for the resulting damage.
- All RuggON warranties are void.

Environmental Hazards

Do not use the LUNA 3 in locations near/with flammable gases or vapor. The use of electrical equipment in explosive environments can be dangerous.

- Turn off the device when near a gas station, fuel depot, chemical plant or a place where blasting operations take place.

Environmental

Ambient Temperature

The LUNA 3 operates on the basis of a passive cooling concept which internal waste heat is released via the housing surface and requires fresh airflow in the environment.

- Operating the LUNA 3 with no fresh cooling air may cause overheating and damage to the device.
- The operating environment should not be enclosed to prevent the cool air being heated by the heat waste from the device.
- Please avoid contact with high temperature area when using if necessary, the contact time should be less than 10 seconds to avoid low temperature scald.

Connecting and Disconnecting External Devices

To prevent the considerable damage, the LUNA 3 and the external device should be disconnected from power when connecting/disconnecting excluding USB devices.

Only Use Authorized Accessories

Only use the supplied cables, power packs and other accessories that have been tested and approved by RuggON. Contact your local distributor for further information.

Radio Transmissions

Permitted Transmission Power

Follow the national regulations for the maximum permitted transmission power.

The operator is solely responsible for this type of operation.

Radio Frequency Limited Locations

Considering the radio frequency limitation in hospitals and aircraft, the LUNA 3 can only be installed with permission.

Industrial computers may affect the function of implanted medical devices such as pacemakers and may cause malfunction.

Cleaning and Servicing

- Disconnect the LUNA 3 from power before cleaning or servicing.
- Never clean the LUNA 3 with compressed air, a pressure washer or a vacuum cleaner.
- If necessary, clean the housing of the LUNA 3 with a damp cloth.
- Clean the touchscreen with a nonabrasive cloth.

Regulatory and Certification

Canada

Contains IC : 25233-AX210D2 / 25233-EM74B

This device complies with Part 15 of the FCC Rules. Operation is subject to the following two conditions:

(1) this device may not cause harmful interference, and (2) this device must accept any interference received, including interference that may cause undesired operation.

CAN ICES-003(B) / NMB-003(B)

This digital apparatus does not exceed the Class B limits for radio noise emissions from digital apparatus as set out in the radio interference regulations of the Canadian Department of Communications.

Le présent appareil numérique n'émet pas de bruits radioélectriques dépassant les limites applicables aux appareils numériques de Classe B prescrites dans le règlement sur le brouillage radioélectrique édicté par le Ministère des Communications du Canada.

Changes and modifications not expressly approved by the manufacturer or registrant of this equipment can void your authority to operate this equipment under Industry Canada rules.

Les changements et modifications non expressément approuvés par le fabricant ou le détenteur de cet

équipement peuvent annuler votre droit à utiliser cet appareil en vertu des règles d'Industrie Canada.

Antenna Statement

Under Industry Canada regulations, this radio transmitter may only operate using an antenna of a type and maximum (or lesser) gain approved for the transmitter by Industry Canada. To reduce potential radio interference to other users, the antenna type and its gain should be so chosen that the equivalent isotropically radiated power (e.i.r.p.) is not more than that necessary for successful communication.

Conformément à la réglementation d'Industrie Canada, le présent émetteur radio peut fonctionner avec une antenne d'un type et d'un gain maximal (ou inférieur) approuvé pour

l'émetteur par Industrie Canada. Dans le but de réduire les risques de brouillage radioélectrique à l'intention des autres utilisateurs, il faut choisir le type d'antenne et son gain de sorte que la puissance isotrope rayonnée équivalente (p.i.r.e.) ne dépasse pas l'intensité nécessaire à l'établissement d'une communication satisfaisante.

Licence exempt

This device complies with Industry Canada licence-exempt RSS standard(s). Operation is subject to the following two conditions:

this device may not cause interference, and

this device must accept any interference, including interference that may cause undesired operation of the device.

Le présent appareil est conforme aux CNR d'Industrie Canada applicables aux appareils radio exempts de licence. L'exploitation est autorisée aux deux conditions suivantes :

l'appareil ne doit pas produire de brouillage, et

l'utilisateur de l'appareil doit accepter tout brouillage radioélectrique subi, même si le brouillage est susceptible d'en compromettre le fonctionnement.

This Class B digital apparatus complies with Canadian ICES- 003.

Cet appareil numérique de la classe B est conforme à la norme NMB-003 du Canada.

This Category II radio communication device complies with Industry Canada Standard RSS-310.

Ce dispositif de radiocommunication de catégorie II respecte la norme CNR-310 d'Industrie Canada.

IMPORTANT NOTE: IC Radiation Exposure Statement

This EUT is compliant with SAR for general population/uncontrolled exposure limits in IC RSS-102 and had been tested in accordance with the measurement methods and procedures specified in IEEE 1528. SAR is measured with the device at 0 mm to the extremity, while transmitting at the highest certified output power level in all frequency bands of the device.

This equipment should be installed and operated with a minimum distance of 0 cm between the radiator and your extremity. This device and its antenna(s) must not be co-located or operating in conjunction with any other antenna or transmitter. The County Code Selection feature is disabled for products marketed in the US/Canada.

IC SAR warning

Radio Frequency (RF) Exposure Information

The radiated output power of the Wireless Device is below the Industry Canada (IC) radio frequency exposure limits. The Wireless Device should be used in such a manner such that the potential for human contact during normal operation is minimized.

This device has been evaluated for and shown compliant with the IC Specific Absorption Rate ("SAR") limits when installed in specific host products operated in portable exposure conditions.

Informations concernant l'exposition aux fréquences radio (RF)

La puissance de sortie émise par l'appareil de sans fil est inférieure à la limite d'exposition aux fréquences radio d'Industrie Canada (IC). Utilisez l'appareil de sans fil de façon à minimiser les contacts humains lors du fonctionnement normal.

Ce périphérique a été évalué et démontré conforme aux limites SAR (Specific Absorption Rate – Taux d'absorption spécifique) d'IC lorsqu'il est installé dans des produits hôtes particuliers qui fonctionnent dans des conditions d'exposition à des appareils portables.

The device could automatically discontinue transmission in case of absence of information to transmit, or operational failure. Note that this is not intended to prohibit transmission of control or signaling information or the use of repetitive codes where required by the technology.

The device for the band 5150-5250 MHz is only for indoor usage to reduce potential for harmful interference to co-channel mobile satellite systems; the maximum antenna gain permitted (for devices in the bands 5250-5350 MHz and 5470-5725 MHz) to comply with the e.i.r.p. limit; and The maximum antenna gain permitted (for devices in the band 5725-5850 MHz) to comply with the e.i.r.p. limits specified for point-to-point and non-point-to-point operation as appropriate, as

stated in section A9.2(3). In addition, High- power radars are allocated as primary users (meaning they have priority) of the band 5250-5350 MHz and this radar could cause interference and/or damage to LE-LAN devices.

FCC



Contain FCC ID: 2ABTU-AX210D2 / 2ABTU-EM74B

This equipment has been tested and found to comply with the limits for a Class B digital device, pursuant to part 15 of the FCC Rules. These limits are designed to provide reasonable protection against harmful interference when the equipment is operated in a commercial environment. This equipment generates, uses, and can radiate radio frequency energy and, if not installed and used in accordance with the instruction manual, may cause harmful interference to radio communications. Operation of this equipment in a residential area is likely to cause harmful interference in which case the user will be required to correct the interference at his own expense.

However, there is no guarantee that interference will not occur in a particular installation. If this equipment does cause harmful interference to radio or television reception, which can be determined by turning the equipment off and on, the user is encouraged to try to correct the interference by one or more of the following measures:

- Reorient or relocate the receiving antenna.
- Increase the separation between the equipment and receiver.
- Connect the equipment into an outlet on a circuit different from that to which the receiver is connected.
- Consult the dealer or an experienced radio / TV technician for help.



Any changes or modifications not expressly approved by the grantee of this device could void the user's authority to operate the equipment.

This device is operation in 5.15 – 5.25GHz/ 5.925-7.125 GHz frequency range, then restricted in indoor use only, Outdoor operations in the 5.15 – 5.25GHz/ 5.925-7.125 GHz is prohibit.

This device is slave equipment; the device is not radaring detection and not ad-hoc operation in the DFS band. The operation of this device is prohibited on oil platforms, cars, trains, boats, and aircraft, except that operation of this device is permitted in large aircraft while flying above 10,000 feet.

Labeling Requirements

This device complies with Part 15 of the FCC Rules. Operation is subject to the following two conditions: (1) this device may not cause harmful interference, and (2) this device must accept any interference received, including interference that may cause undesired operation.

RF Exposure Information (SAR)

This device meets the government's requirements for exposure to radio waves. This device is designed and manufactured not to exceed the emission limits for exposure to radio frequency (RF) energy set by the Federal Communications Commission of the U.S. Government.

The exposure standard employs a unit of measurement known as the Specific Absorption Rate, or SAR. The SAR limit set by the FCC is 1.6 W/kg. Tests for SAR are conducted using standard operating positions accepted by the FCC with the EUT transmitting at the specified power level in

different channels.

The highest SAR value for the device as reported to the FCC is 1.14 W/kg when placed next to the body.

CE and UKCA Marking



This product has passed the CE and UKCA test for environmental specifications when shielded cables are used for external wiring. We recommend the use of shielded cables. Please contact your local representative for ordering information.

This product has passed the CE and UKCA test for environmental specifications. Test conditions for passing included the equipment being operated within an industrial enclosure. In order to protect the product from being damaged by ESD (Electrostatic Discharge) and EMI leakage, we strongly recommend the use of CE and UKCA-compliant industrial enclosure products.

According to ISO / IEC Guide 22 and EN 450 14 Manufacturer's Name: RuggON Corporation.
Manufacturer's Address: 4F, No. 298, Yang Guang St., NeiHu. Taipei, Taiwan, 11491

Declares, under our sole responsibility, that

Product Name: Rugged Tablet

Model Number: Luna3

Conforms to the following Product Specifications:

RED 2014/53/EU; LVD 2014/35/EU; EMC 2014/30/EU

- EN 300 328 V2.2.2
- EN 301 893 V2.1.1
- EN 300 440 V2.2.1
- Draft EN/ BS EN 303 687 V1.0.0
- EN/ BS EN 55032: 2015+A11:2020
- EN/ BS EN 55035: 2017+A11:2020
- EN/ BS EN 301489-1 V2.2.3
- EN/ BS EN 301489-17 V3.2.4
- EN/ BS EN 301489-19 V2.2.1
- EN/BS EN 301489-52 V1.2.1
- EN 303 413 V1.2.1
- EN 301 908-1 V15.1.1
- EN 301 908-2 V13.1.1
- EN 301 908-13 V15.1.1
- EN 50566:2017
- EN 62209-2:2010+A1:2019
- EN/ BS EN 62368-1: 2014 + A11 2017

Supplementary information

In addition, the product is battery powered and the power supply provided with this product has been certified to EN/ BS EN 62368-1: 2014 + A11 2017. As manufacturer, we declare under our sole responsibility that the equipment follows the provisions of the Standards stated above.

Importer of Record

代理商/進口商資訊

<CE>

This device is intended for indoor use only when operating in the frequency range 5150 to 5350/ 5945 to 6425 MHz which is applicable in countries that support WiFi 6E.

<UKCA>

The device is restricted to indoor use only when operating in the 5150 to 5350/ 5925 to 6425 MHz frequency range.

EIRP power:

All operational modes:

Technologies	Frequency range (MHz)	Max. Transmit Power
Bluetooth	2402-2480 MHz	11.05 dBm
Bluetooth LE	2402-2480 MHz	7.52 dBm
WLAN 2.4 GHz	2412-2472 MHz	17.91 dBm
WLAN 5 GHz	5150-5350 MHz	19.65 dBm
WLAN 5 GHz	5470-5725 MHz	19.67 dBm
WLAN 5 GHz	5725-5850 MHz	10.68 dBm
WLAN 6 GHz	5945~6425 MHz	20.28dBm
WCDMA Band 1	1920-1980 MHz	23.85 dBm
WCDMA Band 8	880-915 MHz	23.86 dBm
LTE Band 1	1920-1980 MHz	23.23 dBm
LTE Band 3	1710-1785 MHz	23.18 dBm
LTE Band 7	2500-2570 MHz	22.77 dBm
LTE Band 8	880-915 MHz	23.94 dBm
LTE Band 20	832-862 MHz	23.94 dBm
LTE Band 28	703-748 MHz	23.98 dBm
LTE Band 38	2570-2620 MHz	22.98 dBm
LTE Band 40	2300-2400 MHz	22.99 dBm
LTE Band 42	3400-3600 MHz	22.98 dBm
LTE Band 43	3600-3800 MHz	22.98 dBm

RF Exposure warning

This device meets the EU requirements (2014/53/EU) on the limitation of exposure of the general public to electromagnetic fields by way of health protection.

The limits are part of extensive recommendations for the protection of the general public. These recommendations have been developed and checked by independent scientific organizations through regular and thorough evaluations of scientific studies. The unit of measurement for the European Council's recommended limit for mobile devices is the "Specific Absorption Rate" (SAR), and the SAR limit is 2.0 W/Kg averaged over 10 grams of body tissue. It meets the requirements of the International Commission on Non-Ionizing Radiation Protection (ICNIRP).

For next-to-body operation, this device has been tested and meets the ICNRP exposure guidelines and the European Standard **EN 50566 and EN 62209-2**. SAR is measured with the device directly contacted to the body while transmitting at the highest certified output power level in all frequency bands of the mobile device.

Lithium Battery Safety Statement



Lithium battery inside. Danger of explosion if battery is incorrectly replaced. Replace only with same or equivalent type recommended by battery manufacturer.

WARNING – There are no user-serviceable parts in the batteries. Do not disassemble or open, crush, bend or deform, puncture, or shred the battery. Do not modify or remanufacture, attempt to insert foreign objects into the battery, immerse or expose to water or

other liquids, or expose to fire, explosion, or other hazard. Do not expose to high temperatures.

WARNING – Improper battery use may result in a fire, explosion, or other hazard.

Do not short circuit a battery or allow metallic or conductive objects to contact the battery terminals.

Avoid dropping the device or battery. If dropped, especially on a hard surface, and the user suspects damage to the battery, take it to a service center for inspection.

In the event of a battery leak, do not allow the liquid to come in contact with the skin or eyes. If contact has been made, wash the affected area with large amounts of water and seek medical advice.

Battery usage by children should be supervised.

– disposal of a **battery** into fire or a hot oven, or mechanically crushing or cutting of a **battery**, that can result in an **explosion**;

– leaving a **battery** in an extremely high temperature surrounding environment that can result in an **explosion** or the leakage of flammable liquid or gas;

– a **battery** subjected to extremely low air pressure that may result in an **explosion** or the leakage of flammable liquid or gas.

CAUTION

Risk of explosion if battery is replaced by an incorrect type.

Dispose of used batteries according to the instructions.

The adapter shall be installed near the equipment and shall be easily accessible.

ENERGY STAR



ENERGY STAR qualified products save your money by reducing energy cost and protecting the environment without sacrificing features or performance.

RuggON is proud to offer our customers products with the ENERGY STAR mark.

What is ENERGY STAR?

Products that are ENERGY STAR qualified use less energy and prevent greenhouse gas emissions by meeting strict energy efficiency guidelines set by the U.S. Environmental Protection Agency. RuggON is committed to offering products and services worldwide that help customers save money, conserve energy, and improve the quality of our environment. The more energy we can save through higher energy efficiency, the more we reduce greenhouse gases and the risks of climate change.

More information refers to: www.energystar.gov

ENERGY STAR qualified products:

- Produce less heat and reduce cooling loads, and warmer climates.
- Automatically go into “display sleep” and “computer sleep” within 15 and 30 minutes of inactivity respectively (Refer to “Power and sleep” setting shown in below).
- Wake the computer from sleep mode by pushing keyboard or moving mouse.
- Computers will save more than 80% energy at “sleep” mode.

ENERGY STAR and the ENERGY STAR mark are registered U.S. marks.

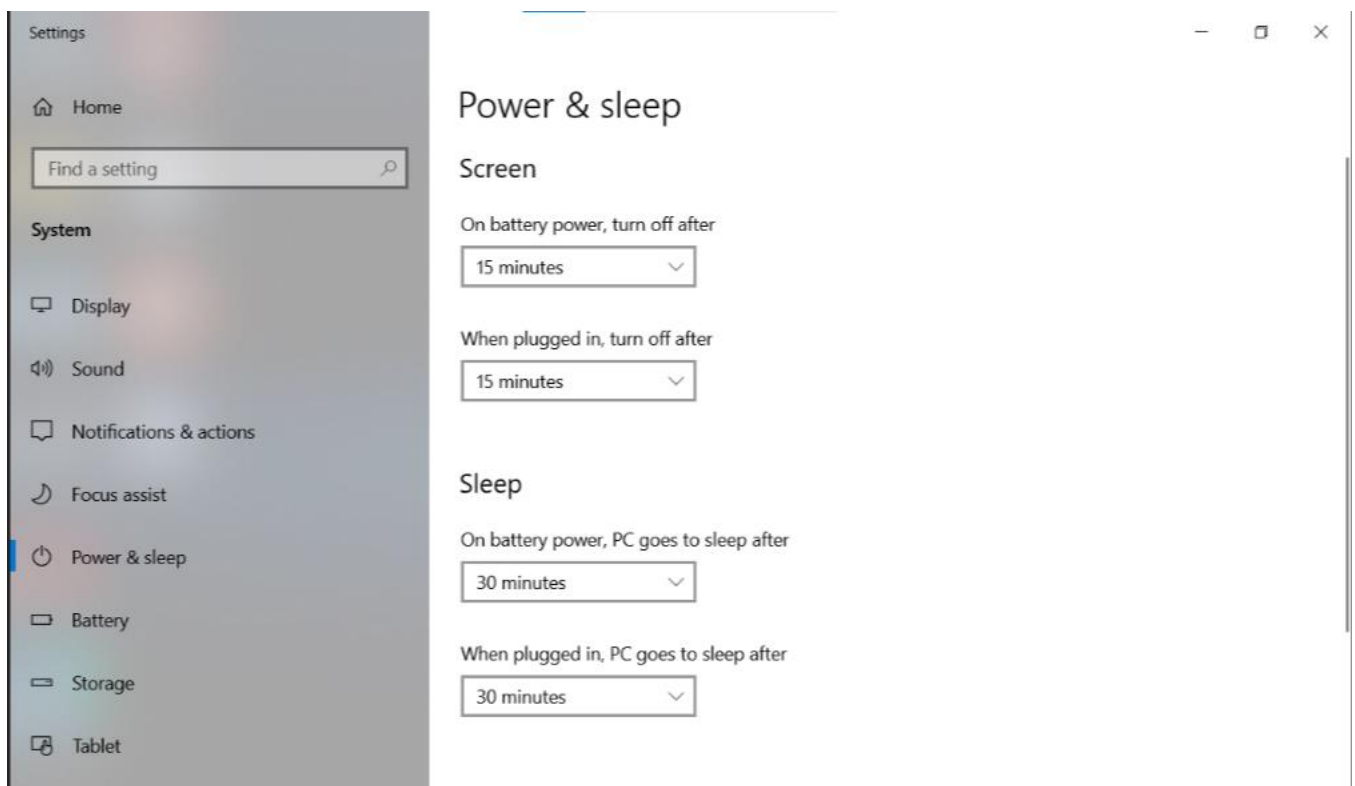

“Power and sleep” setting

Chapter 1. Introduction

The LUNA 3 is a rugged device equipped with 802.11, Bluetooth and GNSS for wireless data communications.

The LUNA 3 is a rugged 8" tablet computer capable of 1280 x 800 resolution.

About This Guide

The LUNA 3 User Manual provides instruction for qualified personnel to use as a guide for setup of the device. This document is not intended to replace the training and expertise of the end-user.

Unpacking the Device

Before you begin the installation or configuration process make sure to inspect all components and accessories. Contact your representative if there are any missing or damaged items. See "*Contacting RuggON*" on page 42.

Parts List

The LUNA 3 is shipped with the following items. All other accessories are sold and ordered separately. For help, contact your local RuggON sales representative. See “*Contacting RuggON*” on page 42.

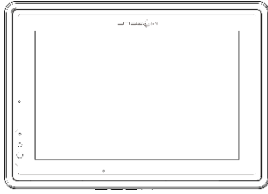

LUNA 3

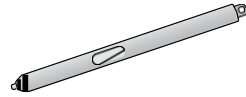

Stylus or Digitizer & Pen holder

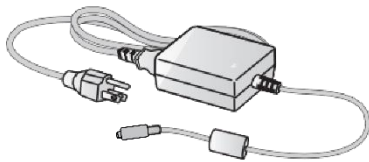

Power Adapter

Identifying the Device

Front View

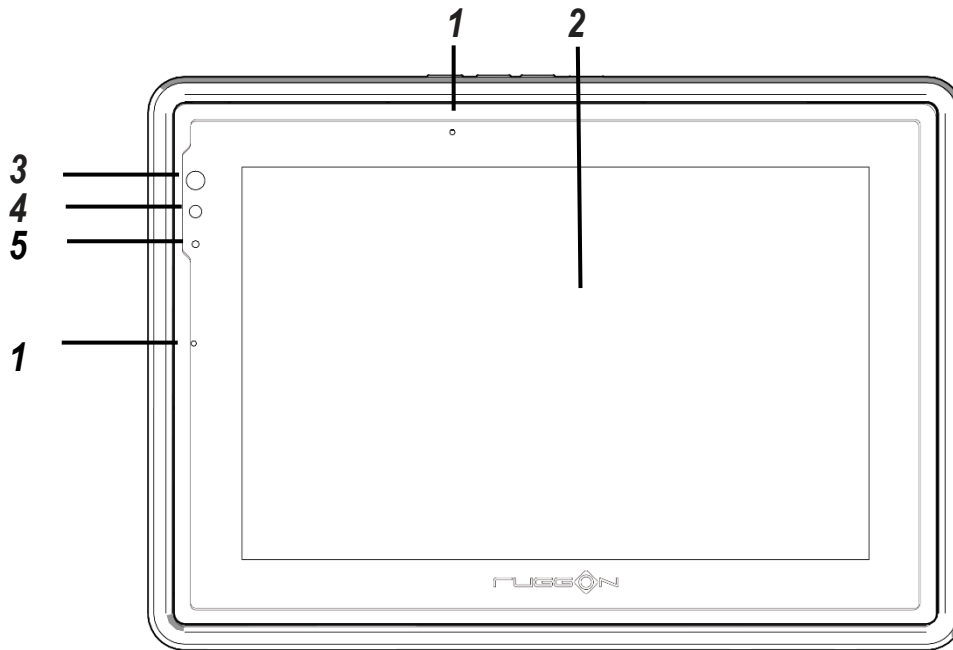

Figure 1. Front View

Table 1. Front View

No	Item	Description
1	Microphone	Integrated microphone.
2	Touch screen	10-point capacitive touch
3	Front camera	2.0 Mega-Pixels camera.
4	Light sensor	Adjusts the screen brightness according to environment light.
5	Power LED	LED indicator for power status

LED Status

Table 2. LED Status

Item	Status	Descrip
Power	Green: On	System power on & battery not charging
	Green: Blinking	System sleep & battery not charging
	Amber: On	System power on & battery charging
	Amber: Blinking	System sleep & battery charging
	Red: On	System power on & battery low (<10%)
	Red: Blinking	System sleep & battery low (<10%)
	Off	System power off & battery not charging

Top View

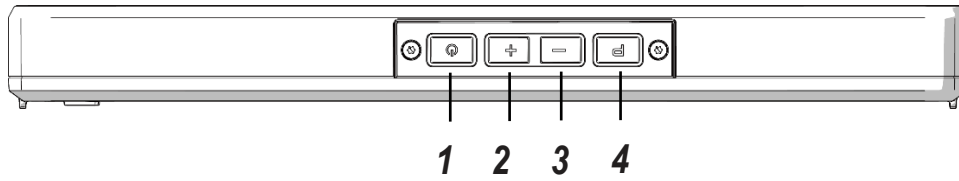

Figure 2. Top View

Table 3. Top View

No	Item	Description
1	Power key	Turns the LUNA 3 on or off.
2	Volume +	Volume increase.
3	Volume -	Volume decrease.
4	P key	Programmable function key.

Bottom View

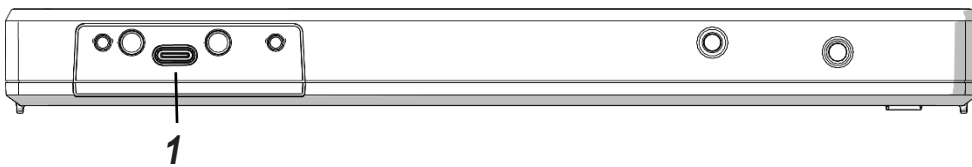

Figure 3. Bottom View

Table 4. Bottom View

No	Item	Description
1	USB 3.1 Type C	Connect USB devices or power to the LUNA 3.

Side View

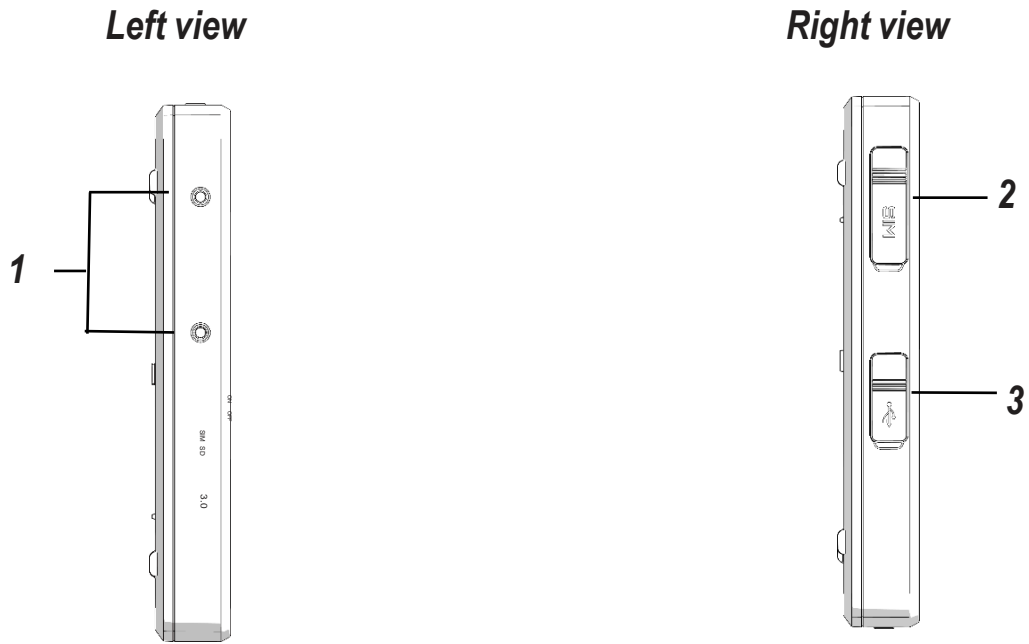

Figure 4. Side Views

Table 5. Side View

No	Item	Descriptio
1	Screw holes	Attach pen holder to these two screw holes.
2	Dual micro-SIM slots	Insert micro-SIM card for 4G LTE communications.
3	USB 3.1 Type C	Connect USB devices or power to the LUNA 3.

Rear View

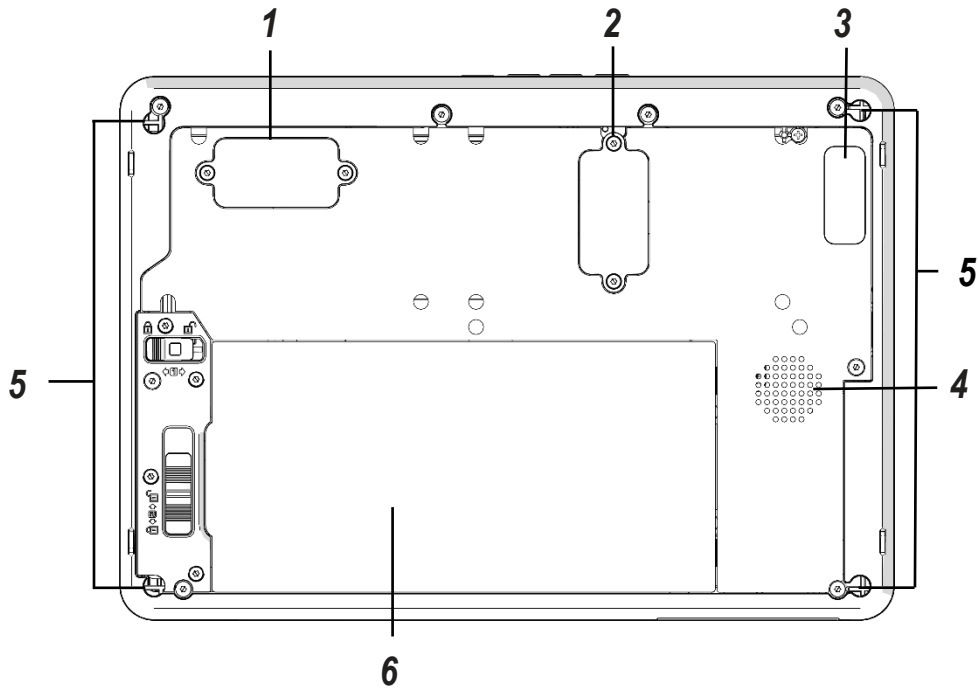

Figure 5. Rear View

Table 6. Rear View

No	Item	Description
1	Expansion bay	Remove the cover to find the expansion connector.
2	Expansion bay	Remove the cover to find the expansion connector.
3	Rear camera	8.0 Mega-Pixels camera with LED auxiliary light
4	Speaker	Embedded speaker for audio output.
5	Securing holes	Secure the optional D-rings for the hand strap and shoulder strap
6	Battery	To install a standard battery or optional extended battery.

Identifying the Digitizer (Optional)

You can use the optional digitizer pen to control your LUNA 3 as with a mouse or keyboard.

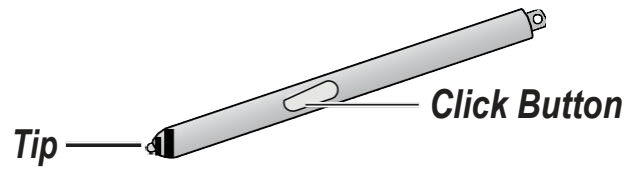

Figure 6. Digitizer View

Please make sure the digitizer pen is perpendicular to the screen for best accuracy.

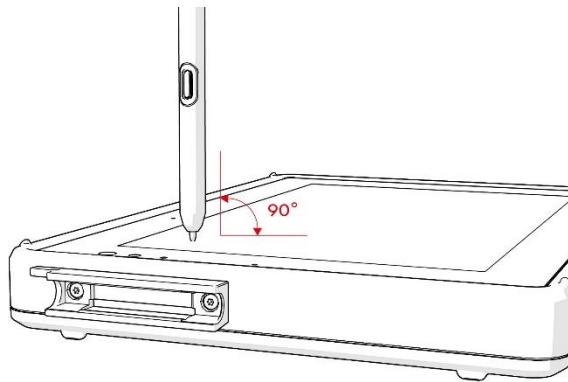

Figure 7. Digitizer Use Note

Touch Screen Features



Always use the point of the digitizer for clicking or making strokes on the touch screen.
Never use an actual pen, pencil, or sharp/abrasive object on the touch screen.

The digitizer is used as if it were a pen or pencil. Touch the screen with the tip of the digitizer then remove the digitizer from the screen.

After each use, replace the digitizer in the digitizer holder for proper care and to preserve the life of the digitizer.

Using a digitizer is similar to moving the mouse pointer then left-clicking icons on a desktop computer screen.

The following actions are available through the use of the digitizer:

- Open applications
- Choose commands in menu
- Select options in dialog box or drop-down menu
- Drag the scroll bar
- Drag across the text to select content
- Place the cursor in a text box before typing

A right click is generated by tapping the mouse icon in the system tray. After tapping, the mouse icon highlights the right button of the icon in red. The next touch screen tap is treated as a right click. The mouse icon returns to the left button highlighted in red so subsequent taps are treated as left clicks.

A digitizer replacement kit is available.



To prevent damage or malfunction, always dry the touch screen when wet.

Chapter 2. Getting Started

This section provides an outline of the steps necessary to setup a new LUNA 3. A detailed guide follows the listed items, see as follows.

For additional technical assistance, contact your RuggON representative. See “*Contacting RuggON*” on page 42.



It is recommended to installing or remove accessories on a clean, well-lit work surface. To protect yourself and the device from electrostatic discharge, wear anti-static wrist straps or place the device on an anti-static mat.

First Time Use

LUNA 3 is under “Battery Ship Mode” and will not power on to preserve the battery and prevent power loss. To enable “Regular Mode” and activate the battery, please connect the power adapter to power on.



Please fill the battery and then discharge it completely once before use to recalibrate the capacity.

Charging the Battery

When you use the AC adapter to connect your LUNA 3 to a power outlet, the standard or extended (optional) battery will automatically begin to recharge.

LUNA 3 supports 2 USB Type C connections and either one can be used for power charging. Connect AC adapter to the either one USB Type C port for charging.

1. Connect the AC adapter to the DC-IN port

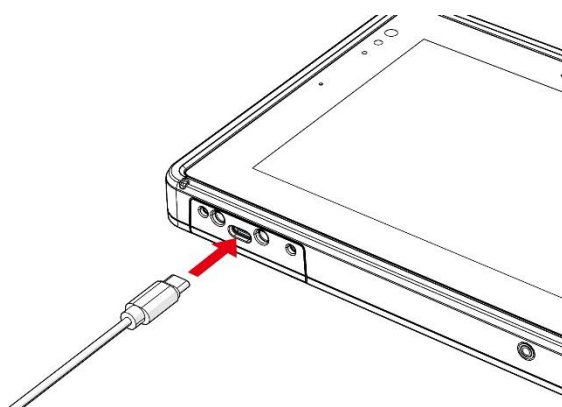

Figure 8. Connecting to the DC-IN port



Please always use AC adapter included in the package. If user wants to use other Type C PD adapter, please make sure that adapter can provide more power than 65 watts.

Powering the Device on and off

Powering On the Device

Only power on the LUNA 3 after connecting all of the peripherals and cabling.

1. Press and hold the power button until the screen lights. The device runs through the startup sequence and powers up.

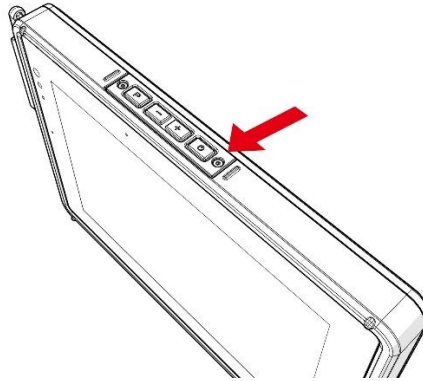



Figure 9. Power On the LUNA 3

Powering Off the Device

- Start screen:
Tap  > **Shut down**.
- Desktop screen:
 1. Tap and hold  at the bottom left corner of the Desktop screen.
 2. Tap **Shut down or sign out** > **Shut down**.
- Both Start screen and Desktop screen:
 1. Display charm bar and tap **Settings**.
 2. Tap **Power** > **Shut down**.

Using the Digitizer

Following the information below when using a digitizer:

- Use only the included digitizer to touch the screen. Do not place any objects on its surface and do not press down strongly with sharp-pointed or hard objects that may leave marks (e.g., nails, pencils and ball point pens).
- Use the digitizer only for touching the screen. Using it for any other purpose may damage the digitizer and result in scratches on the screen.
- The digitizer uses electromagnetic induction and may not work properly near strong electrical field or magnetic field such as:
 - Near AM radio base stations or relay station antennas
 - Near CRT displays that generate strong electromagnetic field noise

Move the digitizer away from such locations so it works properly.

- The pointer cannot follow the digitizer movement if you move the digitizer too quickly.

To make a selection, tap the screen once with the digitizer. To double-click, tap twice without pausing. To do a right-click, tap the screen once and hold the tip of the digitizer on the screen, the right-click icon appears. Press the click button is the same as a right click.

Installing the Pen Holder

Pen holder and screws are included in the package.

1. Install pen holder with screws to the Luna 3.

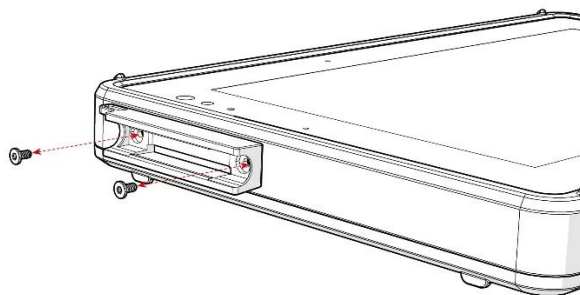

Figure 10. Fixing the Pen Holder

Chapter 3. Operation

Connect to External Cabling

The LUNA 3 has two full function USB Type C port so user can connect USB devices, PD monitor or PD AC power adapter via USB Type C connection.

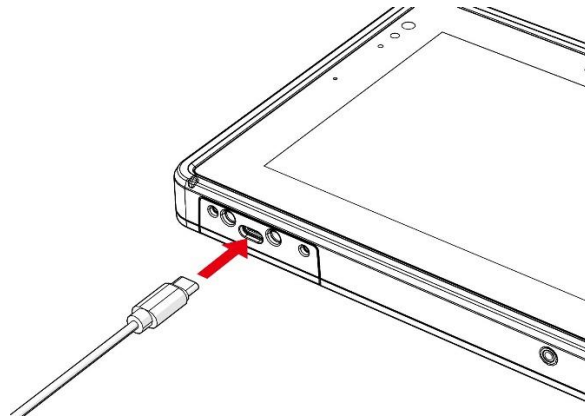

Figure 11. Connect via USB Cabling

Installing SIM Card

Luna 3 includes two micro-SIM card slot for cellular and wireless connection.



Check with your network or cellular service provider for availability and cost rates.

1. Power off Luna 3.
2. Open the lower right I/O compartment cover.
3. Take the micro-SIM card from its packaging. The micro-SIM card has a corner missing. Align the SIM card with the slot making sure that the corners match.
4. Insert the micro-SIM card and press it in until an audible click sounds and close the I/O compartment cover.

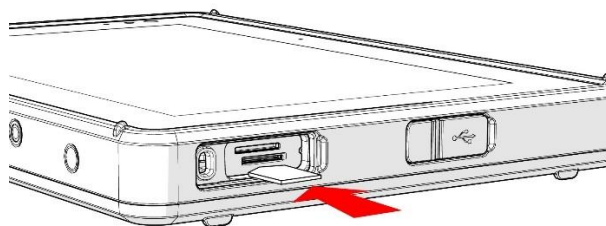

Figure 12. Installing micro-SIM card

Removing SIM card

1. Power off Luna 3.
2. Open the lower right I/O compartment cover.
3. Press the micro-SIM card in and release it. The card springs out.
4. Grasp the micro-SIM card and remove it from the slot and close the I/O compartment cover.

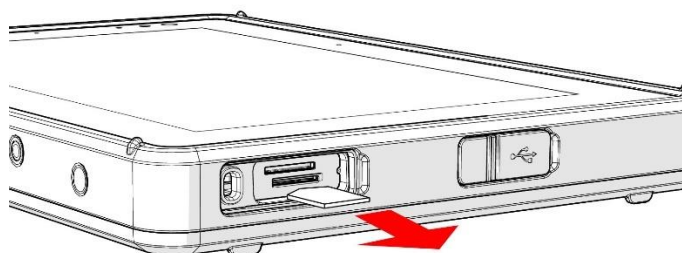

Figure 13. Removing micro-SIM card

Installing the Standard Battery

The following instructions are for both standard and extended batteries. The extended battery is an optional component. Only use components specifically designed for this device. Contact your local representative for ordering information.



Make sure the power switch is switched to ON before installing the standard/extended battery.

1. Place the device display side down on a clean work surface.
2. Locate the battery.

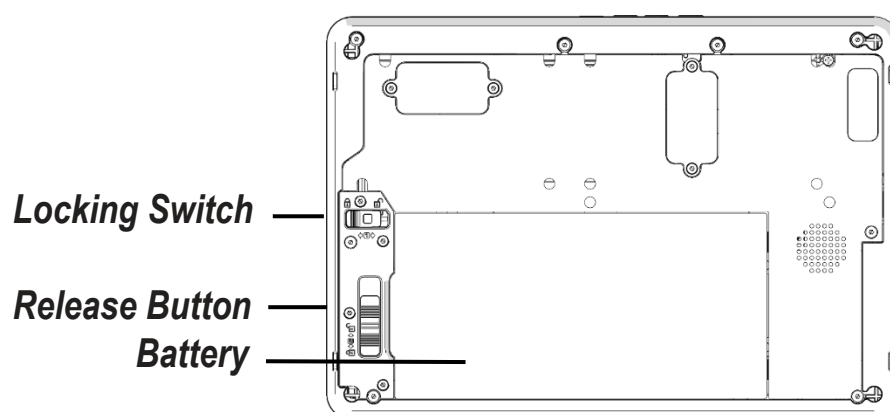

Figure 14. Rear View: Locating the Battery

3. Align the tabs on the battery with the slots on the chassis.
4. Angle the battery in place and set the tabs in the chassis slots.
5. Lower the raised end of the battery and press in place until an audible click is heard.

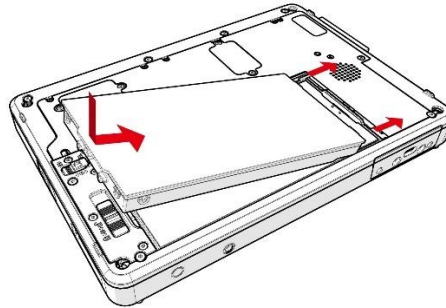

Figure 15. Installing the Battery

6. Slide the locking switch on the top-left side to lock the battery.

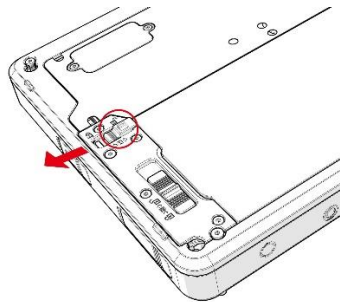

Figure 16. Locking the Battery



Make sure the latch is securely locked to prevent the battery from falling.

Removing the Standard Battery

1. Place the device display side down on a clean work surface.
2. Locate the battery.

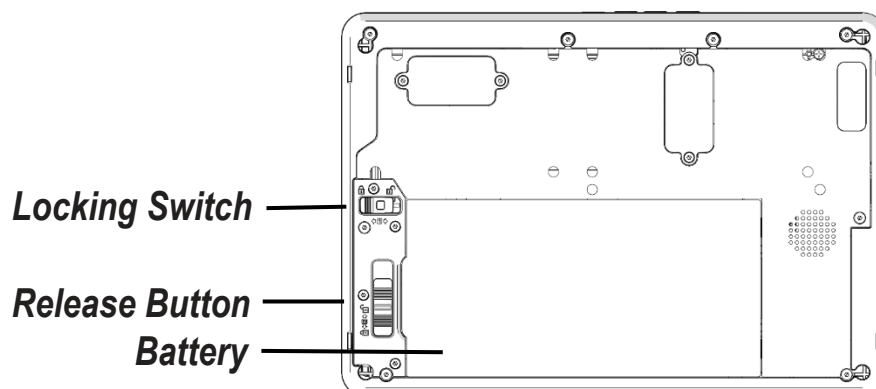

Figure 17. Rear View: Locating the Battery

- Slide the locking switch on the top-left side to the unlock position.

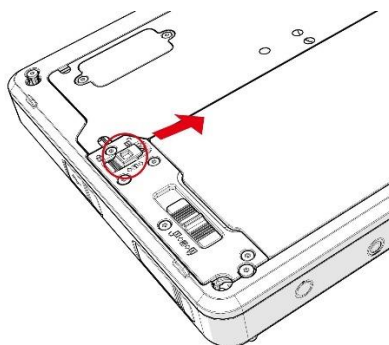

Figure 18. Unlocking the Battery

- Press and hold the release button as shown in the image to release the battery.
- Hold the battery and angle the left side up to remove.

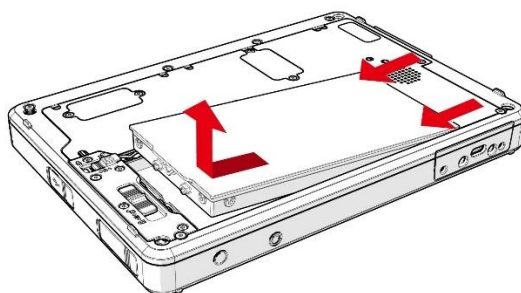

Figure 19. Removing the Battery

Checking Battery Status

You can check battery status via the LED indicators at the back of the battery. Press the battery button the LED indicators will show the battery status as below:

Table 7. Battery LED Status

Battery Status	LED Indicator
Above 75% capacity	Four indicators on
50% - 75% capacity	Three indicators on
25% - 50% capacity	Two indicators on
10% - 25% capacity	One indicator on
Below 10% capacity	One indicator blinking

Connecting to a Wireless Network

Before you can make use of the LUNA 3 wireless functions, you need to connect to a network. The following is a set of procedures for connecting to a wireless network.

1. Before beginning, make sure your Wi-Fi setting is enabled and you are within range of a wireless network. If your Wi-Fi setting is disabled, proceed to step 2.
 - Look at the Network icon located at the right side of the taskbar. If the icon displays an X in a red circle, you are not within range of a wireless network. Move to a different spot until the Wi-Fi icon changes status indicating availability to a wireless network.
2. From any screen, open the Charms bar by sliding your finger inward from the screen's right edge. The Charms bar displays along the screen's right side.
3. In the Charms bar, tap **Settings** to open the **Settings** menu.
4. In **Settings**, tap the Network icon to display the Networks connection settings.
5. The Wi-Fi menu displays. By default, the Wi-Fi menu is set to Off. Tap the bar next to Off to toggle Wi-Fi to On. This enables the Wi-Fi option.
6. Once W-Fi is enabled a listing of all available wireless networks displays. The wireless networks with the strongest signal are atop the list.
7. Select the network you want to connect to, and tap the **Connect** button. You can tap the **Connect Automatically** check box if you connect to this network frequently. If you connect to the network, you are finished with the process. The network is considered an Open unsecured network, no password is required.
8. If a password is required, type the password in the **Enter the network security key** field. Alternatively, you can also push the WPS button on your router to begin the security handshake.
9. Tap **Next** to finish the connection process.

You have successfully connected to a wireless network.

Chapter 4. Using BIOS Setup Utility

Your ruggedized tablet has a BIOS setup utility which allows you to configure important system settings, including settings for the Boot and AP menus as well as the device's basic settings--the system reads the basic settings during initialization in order to boot correctly

When to Use the BIOS Setup Utility

You need to run the BIOS Setup utility when:

- Restoring to BIOS settings to factory default
- Modifying specific hardware settings
- Modifying specific settings to optimize system performance
- Installing Windows operating system

Accessing the BIOS Setup Utility



The BIOS Setup Utility screens shown in this chapter are for your reference only. The actual images or settings on your tablet computer may differ.

The BIOS Setup Utility program may have been updated after the publication of this manual.

To run the BIOS Setup Utility, use the following procedures:

1. Perform one of the following:
 - If the LUNA 3 is powered off
Press the Power button to start up the device. The power LED lights.
Quickly press and hold the P key until the BIOS Post screen displays.
 - If the LUNA 3 is powered on
Press the Power button to shut down the device.
Quickly press and hold the P Key until the BIOS Post screen displays.

The BIOS POST screen appears as shown.

2. From the BIOS POST screen select **App Menu** to open the BIOS Setup Utility.

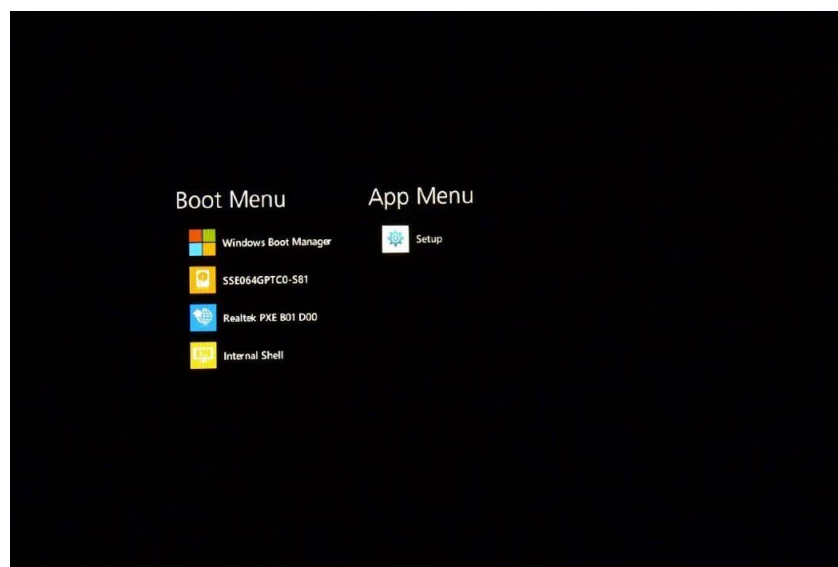

Figure 20. BIOS POST Screen

Using BIOS Setup Utility

Due to the device's fast boot up and boot down time, there is only a small-time frame of a few seconds between the release of the Power button and the opportunity to press the P key. The App Menu displays.



Figure 21. BIOS Setup Utility: App Menu Screen

BIOS Passwords

Setting Up a Supervisor Password

To setup a supervisor password, follow the procedure as described:

1. Go to **APP Menu > Security > Account's Password Status**.

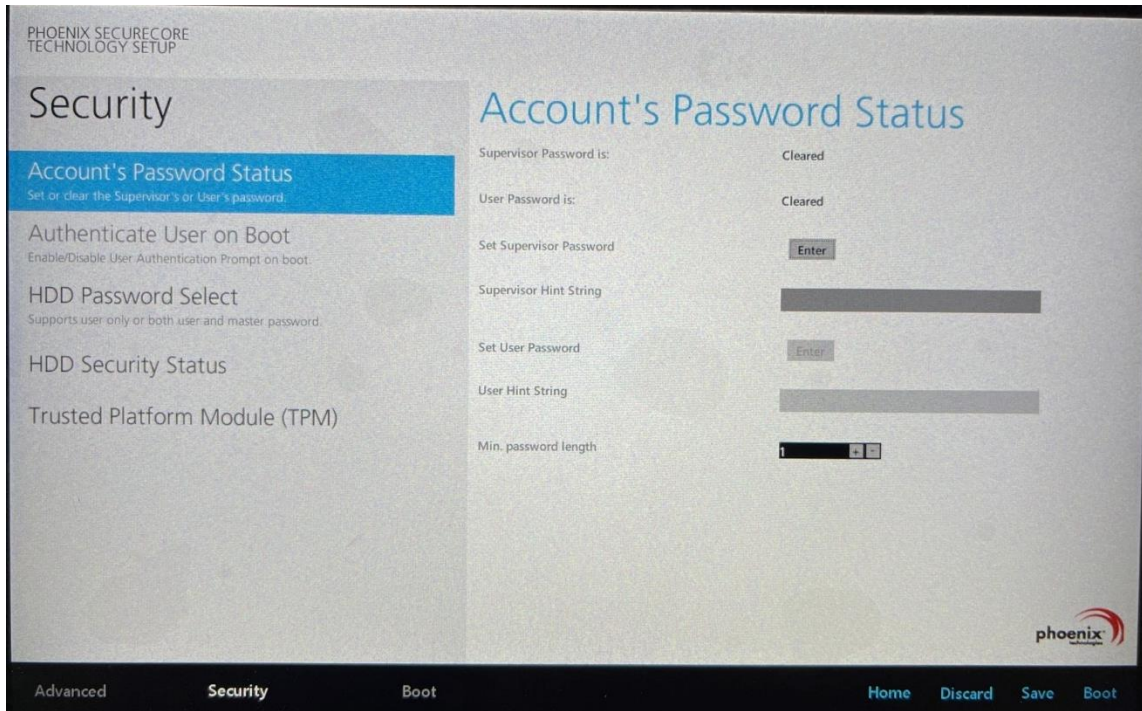

Figure 22. Security > Account's Password Status

2. Tap the **Enter** icon next to **Setup the Supervisor Password** to access the virtual keyboard.
3. Tap the password to use for the Supervisor profile and tap **Enter**.

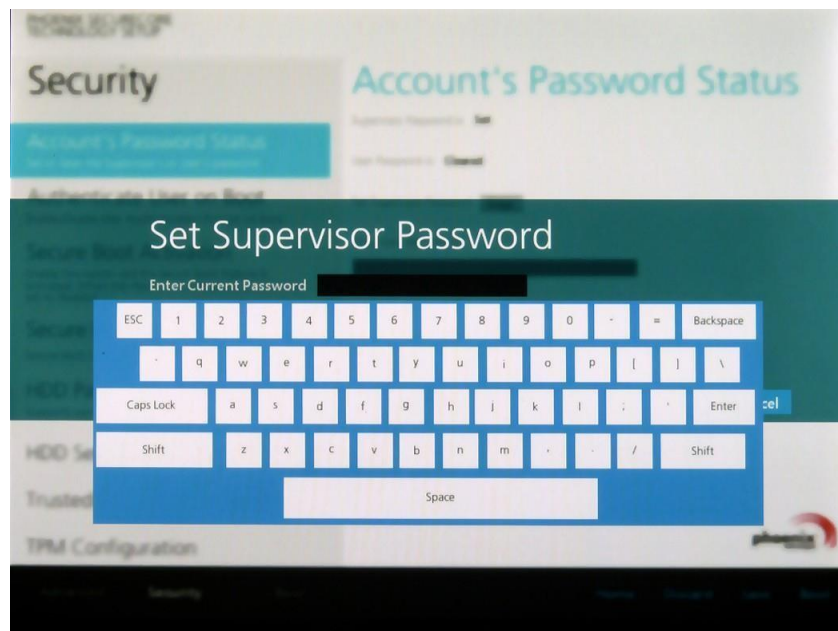

Figure 23. Set Supervisor Password

4. Verification of the password is required. Tap the same password again and tap **Enter** to confirm the new password.
5. Navigate to **APP Menu > Exit**.

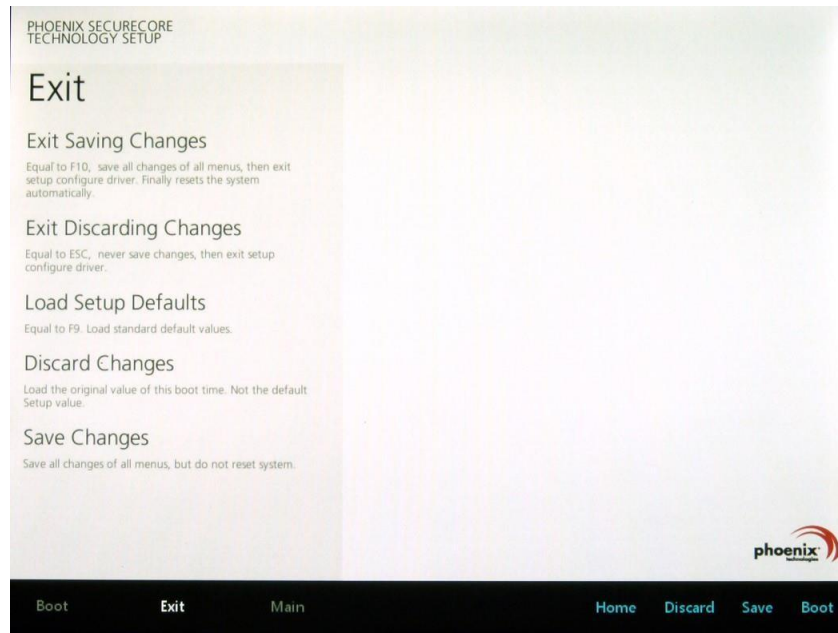

Figure 24. Exit Screen

6. Tap **Exit Saving Changes** to display the confirmation screen.
7. Tap **Yes** to save the new configuration settings.

After setting the Supervisor password, the password is required to access the BIOS Setup Utility.

Changing a Supervisor Password

1. Navigate to **APP Menu > Security > Account's Password Status**.
2. Tap the **Enter** icon next to **Setup Supervisor Password**.
3. Enter the current supervisor password.
4. Enter a new password.
5. Enter the new password again to confirm.
6. Go to **APP Menu > Exit**.
7. Tap **Exit Saving Changes** and tap **Yes** to save the configuration.

Resetting a Supervisor Password

A supervisor password cannot be reset. In the event that you forget the supervisory password, you will need to reflash the BIOS to enter the BIOS menus. Refer to *“Updating BIOS”* on page 31 to reflash the BIOS.

EC/ PD and BIOS

Updating BIOS

This procedure allows you to update and re-flash the system BIOS. Both procedures follow the same steps as described in the following.



Make sure to protect your device from power loss during the BIOS update procedure to prevent irreparable damage to your system's mainboard.

For this procedure, it is highly recommended to connect the device to the AC adapter to prevent a sudden loss of power during the BIOS updating process.

1. Contact your technical sales or technical representative to obtain the correct BIOS file.
2. Copy the BIOS file on to the USB device.
3. Connect the USB device to one of the device's USB ports and power on the LUNA 3.



A USB keyboard is required for entering command.

4. Once the device is on and the Windows 10 Home screen displays open the Notification Center by sliding your finger inward from the screen's right edge.
5. Tap **All Settings** from the displayed menus.

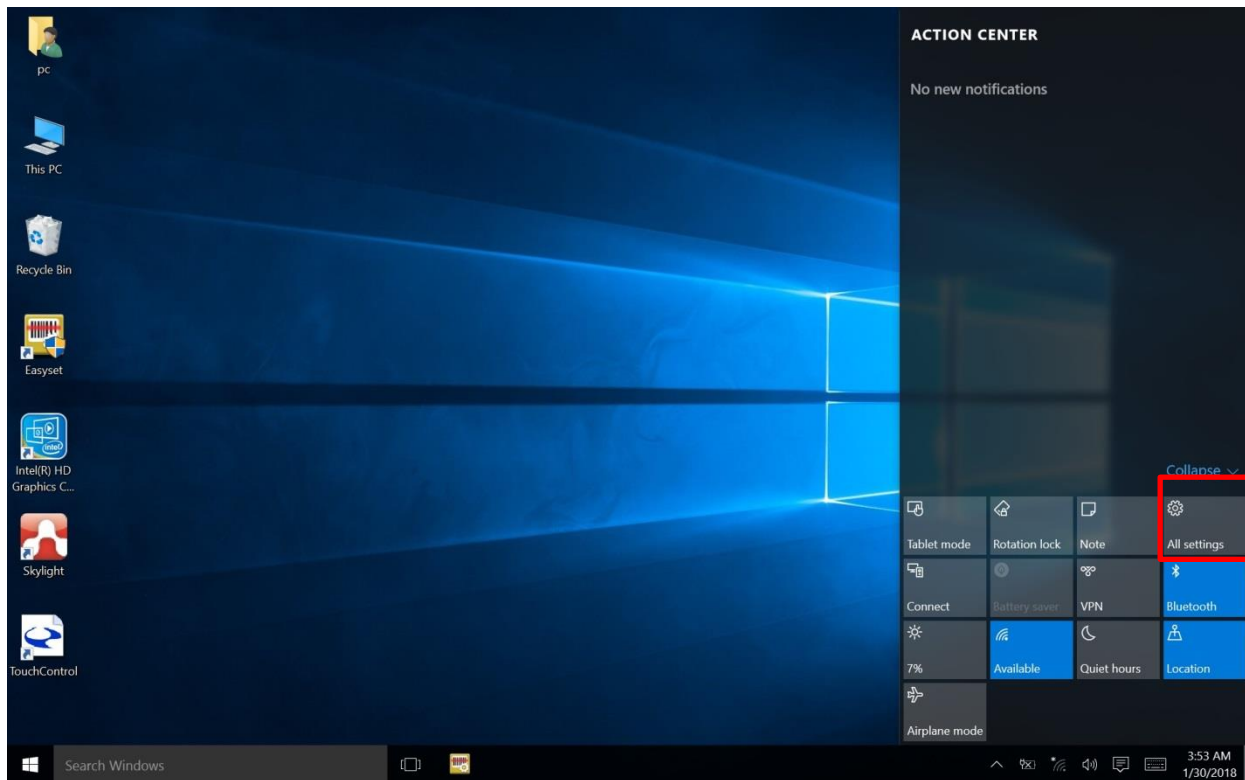

Figure 25. Notification Center > All Settings

6. Tap **Update & Security**.

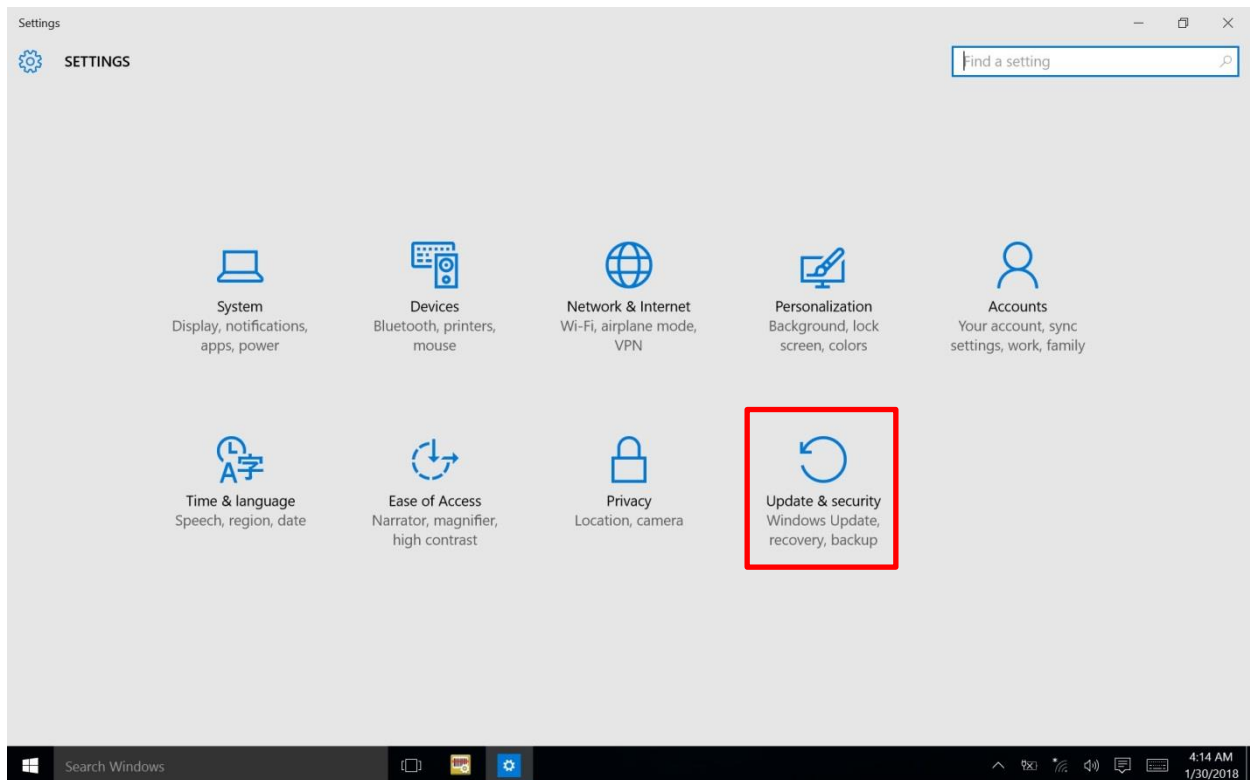

Figure 26. Update & Security

7. From the **Update & Security** screen, tap **Recovery**, then tap **Restart now**

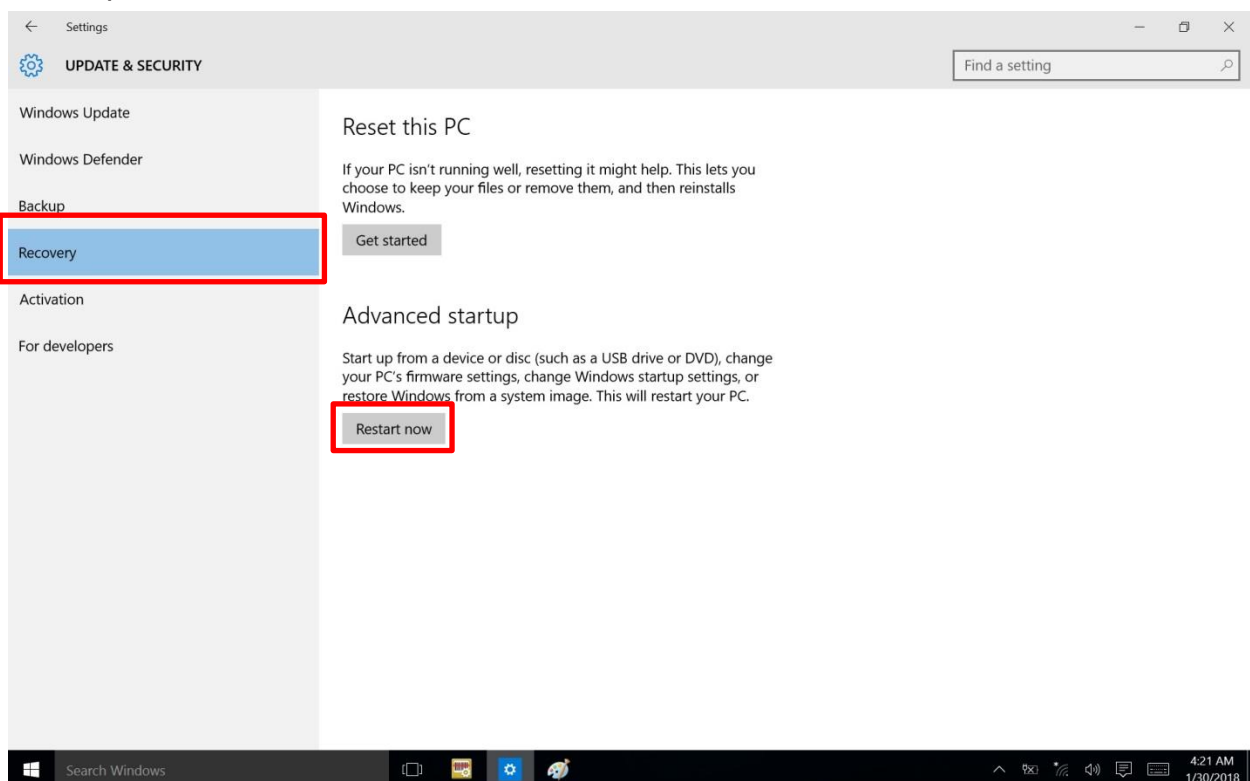

Figure 27. Recovery

8. Tap **Use a device** to select a boot up preference.

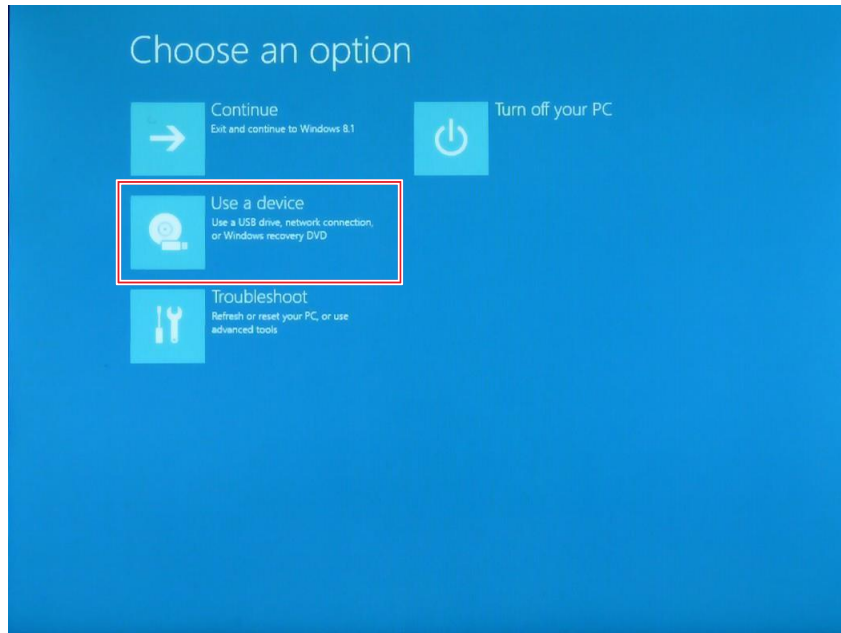

Figure 28. Use a Device

9. From the **Use a device** menu, tap **Internal Shell** to open the command screen.



Make sure connect the LUNA 3 to the AC adapter to prevent a sudden loss of power.

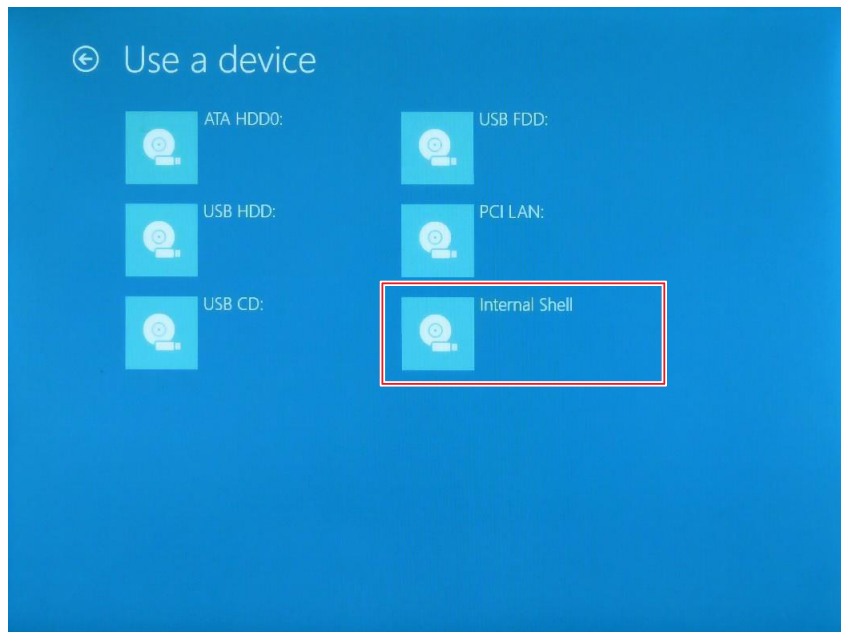

Figure 29. Internal Shell

10. In the command screen, enter `fs1 :` to select the USB device already connected to the device. The command directs you to the USB device's root menu.

```
EFI Shell version 2.31 [4660.22136]
Current running mode 1.1.2
Device mapping table
fs0 :HardDisk - Alias hd19c blk0
      Acpi (PNP0A03.0)/Pci (1310)/Sata (0,0,0)/HD (Part2.Sig632a7c85-549a-4a90-a1fc-809ca105bf3a)
fs1 :Removable BlockDevice - Alias f20a0 blk1
      Acpi (PNP0A03.0)/Pci (1410)/Usb (0,0)
blk0 :HardDisk - Alias hd19c fs0
      Acpi (PNP0A03.0)/Pci (1310)/Sata (0,0,0)/HD (Part2.Sig632a7c85-549a-4a90-a1fc-809ca105bf3a)
blk1 :Removable BlockDevice - Alias f20a0 fs1
      Acpi (PNP0A03.0)/Pci (1410)/Usb (0,0)
blk2 :HardDisk - Alias (null)
      Acpi (PNP0A03.0)/Pci (1310)/Sata (0,0,0)/HD (Part1.Sig4BE671EF-27a4-4990-8B03-86836FBBaEa7)
blk3 :HardDisk - Alias (null)
      Acpi (PNP0A03.0)/Pci (1310)/Sata (0,0,0)/HD (Part3.SigE75F2a22-F220-419B-BEC2-a05073a37fc6)
blk4 :HardDisk - Alias (null)
      Acpi (PNP0A03.0)/Pci (1310)/Sata (0,0,0)/HD (Part4.Sig2CE0675B-5200-4BC6-B761-0965185EA9B4)
blk5 :BlockDevice - Alias (null)
      Acpi (PNP0A03.0)/Pci (1310)/Sata (0,0,0)

Press ESC in 1 seconds to skip startup.nsh, any other key to continue.
Shell: _
```

Figure 30. Internal Shell Command Screen

11. If the BIOS file is in a folder and not in the root directory, navigate to the target folder.
12. Type `wf (.nsh)` and tap Enter. `wf` is the designated BIOS file.
Do not turn off your device or interfere with the reflash process until the process is complete.
13. Once the process is complete, the LUNA 3 automatically reboots. The BIOS is now updated.

Updating EC



Connect the LUNA 3 to the AC adapter to prevent a sudden loss of power.

1. Updating EC requires the use of the Internal Shell Command menu, refer to steps 1 to 12 of “Updating BIOS”.
2. Enter the EC source file folder.
3. In the source folder, enter `f`.
4. Do not turn off your device or interfere with the re-flash process until the process is complete. The system reboots once the process is completed.

Updating PD



Connect the LUNA 3 to the AC adapter to prevent a sudden loss of power.

1. Enter the PD source file folder.
2. Double tap to execute flasher tool named as “ITE_CYPD_UPDATE_UTILITY”.
3. Update console will be displayed. (1) Current version detected. (see [#1]) & (2) Tap [Load Bin File] to load new firmware bin file. (see [#2])



Figure 31. PD update console

4. Open new firmware bin file located in source file folder as well.

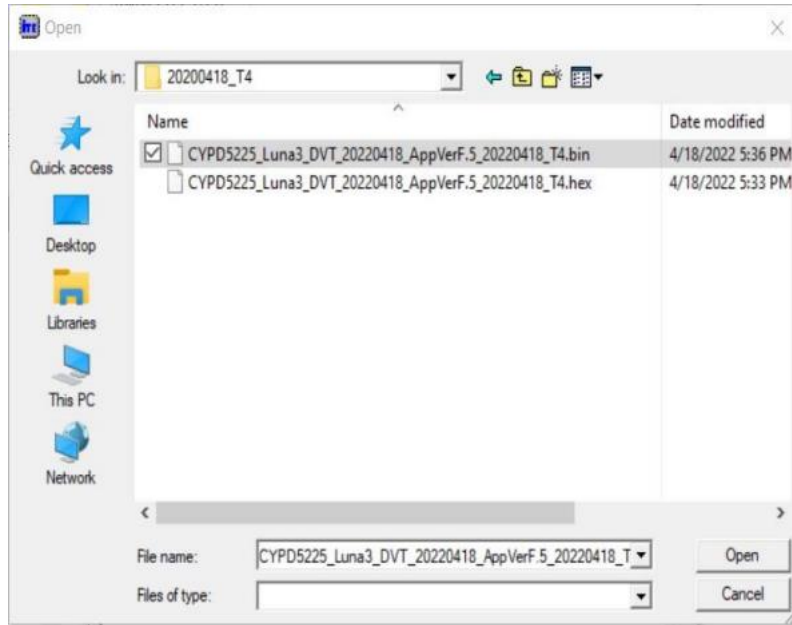

Figure 32. Choose new firmware bin file

5. Tap [Flash Go] to start flashing. (see [#3])



Figure 33. Start flashing

6. Flashing completed. Check new version number. (see [#4])

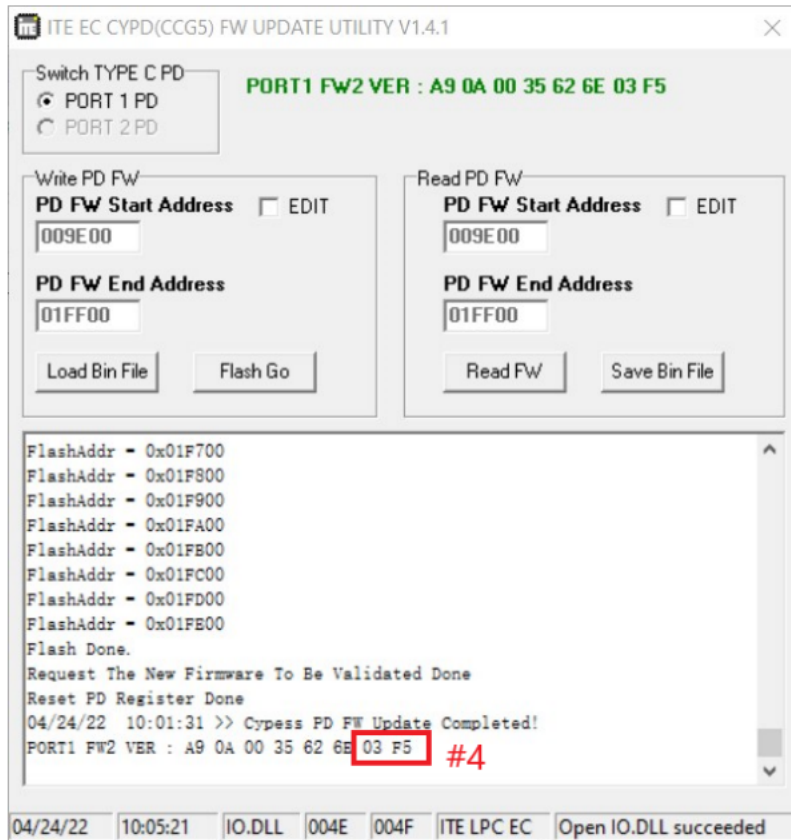

Figure 34. Check new version

7. Tap [X] to close the update flasher tool. Restart Windows to complete update.

Chapter 5. Using the DashON Utility

Overview

The DashON resident program is designed to provide near-instant access to your device's settings and configuration within a single, easy to use interface.

The following information illustrates and describes the various settings available for configuration through the DashON menus.

Important: Do not terminate or remove the DashON program manually or the ambient light sensor and the function buttons will be malfunction.

Download the latest information and documentation through the RuggON official site:

<https://www.ruggon.com/>



Figure 35. DashON Overview

Table 8. DashON functions

Function	Description
EXIT	Minimize DashON and return to the desktop.
Button Lock	Lock or unlock all the physical buttons except Power button.
Touch Setting	Rain (Finger)/ Stylus/ Glove modes change
Charging Current	Adjustable charging current, default 0.5C.
Battery	Shows the battery level or charging status.
Brightness	Adjust brightness level and enable or disable auto brightness function.
Volume Control	Adjust volume level and enable or disable mute function.
SOH	Shows battery health status.
Touch Screen Lock	Lock or unlock the touch screen.
ECO Mode	Disable or enable ECO mode to save battery life when using the device.
Power Plan	Manage how your tablet uses power.
Info Viewer	View system specifications. The menu is for display only.
Display Switch	Choose a display mode when connect to another output device.
GNSS Power	Control GNSS power switch.
Button Setting	Pre-defined functions settings. Supports function button customizing.
Camera	Quick execute Windows camera apps.

Chapter 6. Troubleshooting

Use the troubleshooting tables in this section to fix problems with the Wi-Fi connection, 802.1x security, or general problems with operating the computer.



If you send the computer in for service, it is your responsibility to save the computer data and configuration. RuggON is responsible only for ensuring that the hardware matches the original configuration when repairing or replacing the computer.

Troubleshoot the Wi-Fi Connection

Use this troubleshooting table to help solve problems with your 802.11 radio connection.

- Q.** When you turn on the computer after it was suspended for a while (10 to 15 minutes or longer), it can no longer send or receive messages over the network.
- A.** Host may have deactivated or lost current terminal emulation session. In a TCP/IP direct connect network, turn off the “Keep Alive” message from host to maintain the TCP session while the computer is suspended.
- Q.** The computer is connected to the network and you move to a new site to collect data. Your computer now shows you are not connected to the network.
- A.** Move closer to an access point or to a different location to reestablish communications until you reconnect with the network.
- Q.** The computer appears to be connected to the network, but you cannot establish a terminal emulation session with the host computer.
- A.** There may be a problem with the host computer, or with the connection between the access point and the host computer. Check with the network administrator to make sure the host is running and allowing users to log in to the system.
- Q.** The computer appears to be connected to the network, but the host computer is not receiving any information from the computer.
- A.** There may be a problem with the connection between the access point and the host computer. Check with the network administrator or use your access point user’s manual.
- Q.** A network connection icon appears in the toolbar, but then disappears.
- A.** The computer may not be communicating with the intended access point. Make sure the network name matches the access point network name.
The access point may not be communicating with the server. Ensure the access point is turned on, properly configured, and has 802.1x security enabled.

Troubleshoot Operating the Computer

Use this section to troubleshoot problems that may prevent you from being able to operate the computer.

Q. You press the power button and nothing happens.

A. Make sure that power is connected to the computer.

Q. The computer appears to be locked up and you cannot enter data.

A. Restart the computer.

Call Product Support

Simple instructions please contact the dealer, contact RuggON representative, or leave a message visit the RuggON website at <https://www.ruggon.com>.

To better assist you have the following information ready:

- Configuration number
- Serial number
- Operating system, BIOS, and MCU versions
- Service pack version
- System component versions
- If you are using security, know the type and the full set of parameters

Chapter 7. Maintenance

Cleaning the Device



Danger to electric shock when cleaning or maintaining the LUNA 3.

To avoid electric shock, turn the LUNA 3 off and disconnect it from the power supply before cleaning or maintaining it.

Housing

- The housing of the LUNA 3 is best cleaned with a damp cloth.
- Use compressed air, a high-pressure cleaner or vacuum cleaner may damage the surface.
- Use a high-pressure cleaner, the additional risk of water entering the LUNA 3 may damage the electronics or touch screen.

Touch Screen

- Use neutral detergent or isopropyl alcohol on a clean soft cloth to clean the panel surface.
- Prevent using any kind of chemical solvent, acidic or alkali solution.

Returning the Device

Please put the contents in the original package gently when you need to return the LUNA 3.

Recycle the Device

If you are in United States, you can contact below for recycle the device. We advise our customers to pay UPS to send the recycled device to Potomac eCycle for recycling. Please download the UPS shipping label from RuggON website: Go to RuggON official website, select download, Step1-select Rugged Tablets, Step2-select LUNA3, Step3-select Manuals to download the shipping label. Please print out the shipping label, and then fill out and put the label on the outgoing packages in order to inform Potomac eCycle the recycled device information. The recycler shall meet requirements for legal transportation during the return process, and provides reporting on the types of batteries received.

Potomac eCycle
7941 Wellingford Dr, Manassas, VA 20109
Theory Monsen
571-292-5772

<https://www.ups.com/us/en/support/shipping-support/shipping-special-care-regulated-items/hazardous-materials-guide/how-to-ship-batteries.page>

Battery Change Information

To change battery, please contact below for more information. For battery change request, we will replace the old main battery with new batteries. We will send the replaced old main battery to Potomac eCycle for recycling.

The coin cell battery (CR2032, 3V 220mAh) is not user-removable. If users have any questions, please contact Ubiqconn Service Center

Ubiqconn Service Center
Contact person: Kevin Lin
Email address: Kevin_Lin@ubiqconn.com
Phone: +886-2-82272868 ext 247

Contacting RuggON

If you experience technical difficulties, please consult your distributor or contact the technical services department:

Please visit RuggON website (<https://www.ruggon.com>) for more information. RuggON will provide maintenance services for at least 3 years after purchase.

