



# **MT7000**

## **User's Manual**



v1.7



# Contents

<b>CONTENTS</b> .....	<b>2</b>
<b>SAFETY PRECAUTIONS</b> .....	<b>5</b>
<b>REGULATORY AND CERTIFICATION</b> .....	<b>7</b>
FCC.....	7
RF EXPOSURE WARNING.....	8
CE MARKING.....	8
LITHIUM BATTERY SAFETY STATEMENT.....	11
<b>CHAPTER 1. PRODUCT INTRODUCTION</b> .....	<b>12</b>
HARDWARE SPECIFICATIONS.....	12
ENVIRONMENT.....	13
I/O PORTS.....	14
DIMENSION AND WEIGHT .....	15
MT7000 Standard.....	15
PACKAGE LIST.....	16
<b>CHAPTER 2. HARDWARE INSTALLATION</b> .....	<b>17</b>
MSATA MODULE .....	17
Installing/Removing a mSATA Module.....	17
INSTALLING/REMOVING THE WI-FI MODULE.....	19
INSTALLING/REMOVING THE SIM CARD .....	21
Internal SIM slot.....	21
External SIM slot.....	22
INSTALLING/REMOVING THE WWAN MODULE.....	24
Optional WWAN Module Installation.....	24
INSTALLING WWAN/WLAN ANTENNAS.....	26
Internal Antennas.....	26
External Antenna.....	26
<b>CHAPTER 3. HARDWARE MOUNTING</b> .....	<b>28</b>
<b>CHAPTER 4. START UP</b> .....	<b>29</b>
POWERING THE SYSTEM.....	29

Installation Instructions.....	29
Connector Power.....	30
Backup Battery.....	32
Powering Down the System.....	32
LED STATUS.....	33
TURN ON-SCREEN DISPLAYS ON/OFF.....	34
ADJUST THE SPEAKER VOLUME.....	34
AUTO-BRIGHTNESS ADJUSTMENT.....	35
INTERNAL MICROPHONE.....	35
PROGRAMMABLE BUTTONS.....	35
HARDWARE RESET BUTTON.....	36
POWER MANAGEMENT.....	37
<b>CHAPTER 5. JUMPERS AND CONNECTORS .....</b>	<b>38</b>
BOTTOM VIEW .....	38
EXTERNAL CONNECTORS PIN ASSIGNMENTS .....	39
Power Connector.....	39
RS-232 Port (COM1).....	40
USB and RS-232/422/485 Port (COM2).....	41
Digital I/O and CANbus Port.....	43
<b>CHAPTER 6. DASHON SETTING .....</b>	<b>44</b>
DEVICE INFORMATION.....	45
VEHICLE STATUS.....	46
COMMUNICATION SETTING.....	47
Enable/ Disable Module.....	47
WWAN Communication Setting.....	48
SYSTEM STATUS & SETTING .....	49
Power Automatic Turn Off Behavior.....	49
Power Management Setup.....	49
Wake up Setting.....	54
I/O Configuration.....	56
Brightness Setting.....	56
Watchdog Timer.....	57
Programmable Button.....	60
LOCATION AND SENSOR.....	62

Enable/ Disable GPS Receiver .....	64
Serial Port Setting .....	64
Baud Rate Setting .....	65
<b>CHAPTER 7. MAIN BIOS SETTING .....</b>	<b>66</b>
SET BOOT SEQUENCE.....	66
SET THE SYSTEM CONFIGURATION.....	67
Setting the System Date.....	67
Setting the System Time .....	67
SYSTEM INFORMATION.....	68
BOOT FEATURES.....	68
MISCELLANEOUS CONFIGURATION .....	69
ACCOUNT'S PASSWORD SETTING.....	69
HDD SECURITY SETTING .....	70
<b>CHAPTER 7. WI-FI HOTSPOT SETUP .....</b>	<b>71</b>

# Safety Precautions

1. Read these safety instructions carefully.
2. Keep this user's manual for later reference.
3. Disconnect this equipment from any power source before cleaning. Use a damp cloth. Do not use liquid or spray detergents for cleaning.
4. For plug-in equipment, the power outlet socket must be located near the equipment and must be easily accessible.
5. Keep this equipment away from humidity.
6. Put this equipment on a stable surface during installation. Dropping it or letting it fall may cause damage.
7. Do not leave this equipment in either an unconditioned environment or in an above 40°C storage temperature as this may damage the equipment.
8. Make sure the voltage of the power source is correct before connecting the equipment to the power outlet.
9. Place the power cord in a way so that people will not step on it. Do not place anything on top of the power cord. Use a power cord that has been approved for use with the product and that it matches the voltage and current marked on the product's electrical range label. The voltage and current rating of the cord must be greater than the voltage and current rating marked on the product.
10. All cautions and warnings on the equipment should be noted.
11. If the equipment is not used for a long time, disconnect it from the power source to avoid damage by transient overvoltage.
12. Never pour any liquid into an opening. This may cause fire or electrical shock.
13. Never open the equipment. For safety reasons, the equipment should be opened only by qualified service personnel.
14. If one of the following situations arise, get the equipment checked by service personnel:
  - a. The power cord or plug is damaged.
  - b. Liquid has penetrated into the equipment.
  - c. The equipment has been exposed to moisture.
  - d. The equipment does not work well, or you cannot get it to work according to the user's manual.
  - e. The equipment has been dropped and damaged.

- f. The equipment has obvious signs of breakage.
- 15. Do not place heavy objects on the equipment.
- 16. The unit uses a three-wire ground cable which is equipped with a third pin to ground the unit and prevent electric shock. Do not defeat the purpose of this pin. If your outlet does not support this kind of plug, contact your electrician to replace your obsolete outlet.
- 17. **CAUTION:** DANGER OF EXPLOSION IF BATTERY IS INCORRECTLY RE- PLACED. REPLACE ONLY WITH THE SAME OR EQUIVALENT TYPE REC- OMMENDED BY THE MANUFACTURER. DISCARD USED BATTERIES ACCORDING TO THE MANUFACTURER'S INSTRUCTIONS.

# Regulatory and Certification

## FCC

This device complies with Part 15 of the FCC Rules. Operation is subject to the following two conditions:

1. This device may not cause harmful interference.
2. This device must accept any interference received, including interference that may cause undesired operation.

This equipment has been tested and found to comply with the limits for a Class B digital device, pursuant to Part 15 of the FCC Rules. These limits are designed to provide reasonable protection against harmful interference in a residential installation. This equipment generates, uses, and can radiate radio frequency energy and, if not installed and used in accordance with the instructions, may cause harmful interference to radio communications. However, there is no guarantee that interference will not occur in a particular installation. If this equipment does cause harmful interference to radio or television reception, which can be determined by turning the equipment off and on, the user is encouraged to try to correct the interference by one or more of the following measures:

- Reorient or relocate the receiving antenna.
- Increase the separation between the equipment and the receiver.
- Connect the equipment into an outlet on a circuit different from that to which the receiver is connected.
- Consult the dealer or an experienced radio/TV technician for help.

Shielded interconnect cables and shielded power cable must be employed with this equipment to insure compliance with the pertinent RF emission limits governing this device. Changes or modifications not expressly approved by the system's manufacturer could void the user's authority to operate the equipment.



Any changes or modifications not expressly approved by the party responsible for compliance could void the user's authority to operate the equipment.

This device is operable in 5.15 – 5.25GHz frequency range, then restricted in indoor use only, Outdoor operations in the 5.15 – 5.25GHz is prohibitive.

# RF Exposure Warning

This equipment must be installed and operated in accordance with provided instructions and the antenna(s) used for this transmitter must be installed to provide a separation distance of at least 20 cm from all persons and must not be co-located or operating in conjunction with any other antenna or transmitter. End-users and installers must be provide with antenna installation instructions and transmitter operating conditions for satisfying RF exposure compliance.

# CE Marking

This product has passed the CE test for environmental specifications when shielded cables are used for external wiring. We recommend the use of shielded cables. Please contact your local representative for ordering information.

This product has passed the CE test for environmental specifications. Test conditions for passing included the equipment being operated within an industrial enclosure. In order to protect the product from being damaged by ESD (Electrostatic Discharge) and EMI leakage, we strongly recommend the use of CE-compliant industrial enclosure products.

MT7000 Conforms to the Following Specifications

## **LVD 2014/35/EU**

EN 60950-1:2005(Second Edition) + Am 1:2009 + Am 2:2013

## **EMCD 2014/30/EU**

EN 55032

EN 55035

## **RED 2014/53/EU**

ETSI EN 300 440-2

ETSI EN 300 328

ETSI EN 301 893



ETSI EN 301 489-1  
 ETSI EN 301 489-17  
 EN 62311

	BE	BG	CZ	DK	DE	EE	IE
	EL	ES	FR	HR	IT	CY	LV
	LT	LU	HU	MT	NL	AT	PL
	PT	RO	SI	SK	FI	SE	

### RF Power Table

2.4GHzConducted result

Ant Gain: 2.92

<b>WLAN</b>				
CH	802.11b	Chain	Avg(dBm)	EIPR
1	2412	A	14.96	17.88
7	2442	A	15.21	18.13
13	2472	A	15.25	18.17
CH	802.11g	Chain	Avg(dBm)	EIPR
1	2412	A	15.24	18.16
7	2442	A	15.47	18.39
13	2472	A	15.34	18.26
CH	802.11n20		Avg(dBm)	EIPR
1	2412		16.22	19.14
6	2442		15.91	18.83
9	2472		16.03	18.95
CH	802.11n40		Avg(dBm)	EIPR
3	2422		16.05	18.97
7	2442		16.29	19.21
11	2462		16.43	19.35

Ant Gain: 2.92

<b>BT</b>			
1M		Avg(dBm)	EIPR
2402		2.79	5.71

2441	3.55	6.47
2480	3.9	6.82
3M	Avg(dBm)	EIPR
2402	-1.72	1.2
2441	-1.22	1.7
2480	-0.55	2.37
Channel	Avg(dBm)	EIPR
2402	1.32	4.24
2440	2.04	4.96
2480	2.68	5.6

2.4GHzConducted result

<b>WLAN</b>				
CH	802.11a	Chain	Avg(dBm)	EIPR
36	5180	B	15.61	19.71
64	5320	B	15.07	19.29
100	5500	B	14.98	19.09
140	5700	B	15.87	19.98
CH	802.11n20		Avg(dBm)	EIPR
36	5180		16.85	20.95
64	5320		15.42	19.64
100	5500		16.33	20.44
140	5700		16.74	20.85
CH	802.11n40		Avg(dBm)	EIPR
36	5190		14.36	18.46
64	5310		13.34	17.56
100	5510		16.67	20.78
140	5670		16.55	20.66
CH	802.11ac80		Avg(dBm)	EIPR
36	5210		14.32	18.42
64	5290		14.65	18.87
100	5530		14.42	18.53
140	5610		16.74	20.85

Band 1 Gain:	4.1
Band 2 Gain:	4.22
Band 3 Gain:	4.11
Band 4 Gain:	4.11

## Lithium Battery Safety Statement

Lithium battery inside. Danger of explosion if battery is incorrect replaced. Replace only with the same or equivalent type of battery recommended by battery manufacturer.



Disposal of a BATTERY into fire or a hot oven, or mechanically crushing or cutting of a BATTERY, that can result in an EXPLOSION;

Leaving a BATTERY in an extremely high temperature surrounding environment that can result in an EXPLOSION or the leakage of flammable liquid or gas;

A BATTERY subjected to extremely low air pressure that may result in an EXPLOSION or the leakage of flammable liquid or gas.

THIS PRODUCT CONTAINS LITHIUM-ION BATTERY PACKS. IT MUST BE DISPOSED OF PROPERLY. CONTACT LOCAL ENVIRONMENTAL AGENCIES FOR INFORMATION ON RECYCLING AND DISPOSAL PLANS IN YOUR AREA.

# Chapter 1. Product Introduction

MT7000 is an in-vehicle terminal with 7” high resolution display and 500nits brightness, and is flexible to support a wide range of wireless connection capability. The device is well-suited for fleet management, asset management, EOBR and ELDs application.

It is compliant to ISO 7637-2, SAE J1455 and SAE J1113 and its optimized power system is designed for cold cranking, load dump, transient voltage and ESD.

The device is engineered with IP65 protection rating, a wide temperature design, wide input range, and rich expanding interfaces that support in-vehicle connectivity.

## Hardware Specifications

Item	Description
Processor	Intel® Atom™ E3826 1.46GHz, optional Intel® Atom™ E3815 1.46GHz
Memory	DDR3L 2GB SDRAM up to 4GB (by request)
Storage	mSATA SSD x 1, Micro SD slot x 1
Display	7-inch WSVGA (1024 x 600), 500 nits Viewing angel: 145(H)/ 160(V) (CR>10)
Touch Panel	Projected Capacitive Touch Screen
Wireless Connectivity	802.11 ac/a/b/g/n 2x2 Bluetooth 4.0 + HS GPS / QZSS or GLONASS (COM3) 1 mini PCIe slot (full size) for cellular module External SMA female connectors for wireless expansion (Wi-Fi/WWAN and GPS)
Power Input	9-36VDC,3.5A
Power Consumption	25W: 25°C, run Burn-In test and without USB Type C, RS232 loading 9W: 25°C, idle mode, no RS232 loading and 200nits LCD brightness
Battery	LI-ION battery pack for graceful shutdown
Housing (Mechanical)	PC+ABS, fanless design
Certification	CE, FCC, CB , E-Mark

# Environment

- Operating temperature:
  - -30°C (-22°F) to 60°C (140°F)
  - In accordance with MIL-STD-810G CHANGE1 Method 501.6 High Temperature Procedure II - Operation
  - In accordance with MIL-STD-810G CHANGE1 Method 502.6 Low Temperature Procedure II – Operation
- Storage temperature:
  - -30°C (-22°F) to 70 °C (158°F)
  - In accordance with MIL-STD-810G CHANGE1 Method 501.6 High Temperature Procedure I – Storage
  - In accordance with MIL-STD-810G CHANGE1 Method 502.6 Low Temperature Procedure I - Storage
- Relative humidity: 5% to 95% @ 30°C (86°F) to 60°C (140°F) non-condensing in accordance with MIL-STD-810G CHANGE1 Method 507.6 Humidity Procedure II Aggravated Cycles (Fig 507.6-7)
- Vibration Test:
  - Operating: MIL-STD-810G CHANGE1 Method 514.7 Category 4, Fig 514.7C-2 Common carrier (US highway truck vibration exposure); Fig 514.7C-3 Composite two-wheeled trailer; Fig 514.7C-4 Composite wheeled vehicle
  - Non-Operating: MIL-STD-810G CHANGE1 Method 514.7 Category 24, Fig 514.7E-1 (General minimum integrity exposure)
- Shock Test:
  - Operation: MIL-STD-810G CHANGE1 Method 516.7 Procedure 1 Functional Shock
  - Non-Operation: MIL-STD-810G CHANGE1 Method 516.7 Procedure V Crash Hazard Shock

# I/O Ports

Item	Description
Serial	RS-232 x 1 with 0/5/12V support 0.6A (COM1) RS-232 TX, RX/422/485 x 1 (COM2)
USB	USB 3.0 x 1 (inside the side door cover) USB 2.0 x 1
Ethernet	Gigabit RJ45 x 1
Digital I/O	2 DI + 2 DO SOS x 1
CAN	CAN bus (SAE J1939 supported) x 1
Audio	Headset jack x 1 Internal MIC-in x 1
Speaker	Waterproof speakers 2W

# Dimension and Weight

## MT7000 Standard

Dimension: 219.98 x 151.98 x 40.8mm / 8.66 x 5.98 x 1.60in. (W x H x D)

Weight: 1.25 kg/ 2.76 lbs. (with mSATA)

### Front View Dimension

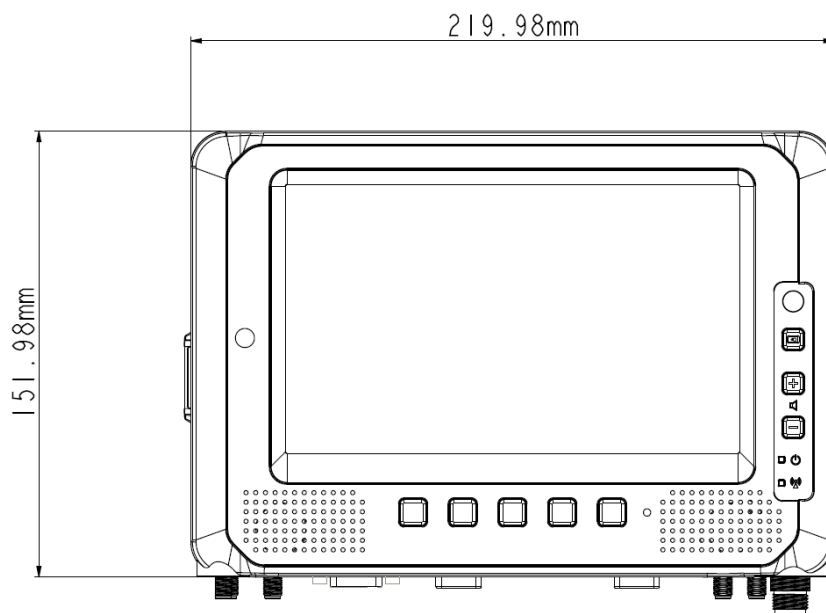

### Side View Dimension

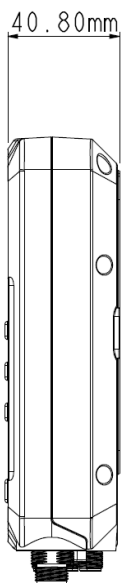

# Package List

Before you begin the installation or configuration process, make sure to inspect all the components and accessories. Contact your representative if there are any missing or damaged items.

Please verify the delivery of the contents upon receipt

- MT7000 in-vehicle terminal
- Quick Start Guide
- Circular power connector to Fork Terminals (Length: 300mm)
- 2-feet DB15 male connector cable with multiple end
- 2-feet DB15 male connector cable (no termination)

NOTE: The packaging material has been selected to optimally protect your device. After unpacking, store the original packaging material in the event that you need to return for shipment.



# Chapter 2. Hardware Installation

This chapter provides information for the installation and removal of mSATA and mini PCIe card.

## mSATA Module

Prevention of EMI interference in this device is not guaranteed if the original components are replaced.

A single mSATA module slot is available for memory expansion. The device supports up to 256GB.

### Installing/Removing a mSATA Module

1. Shut down the system properly and disconnect the device from all power sources.
2. Un-mount the device from the mounting apparatus; make sure that the display surface is protected.
3. Remove the screws securing the service cover.

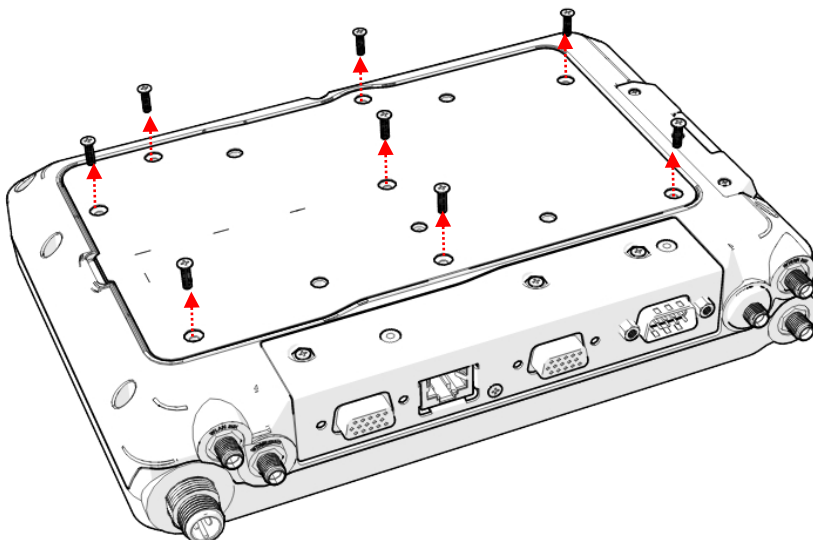

4. Remove the service door.

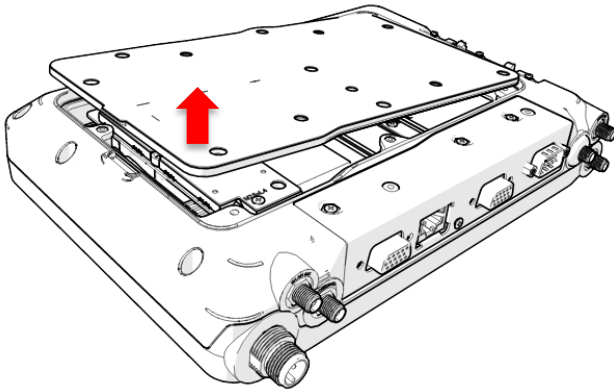

5. Remove the shielding can.

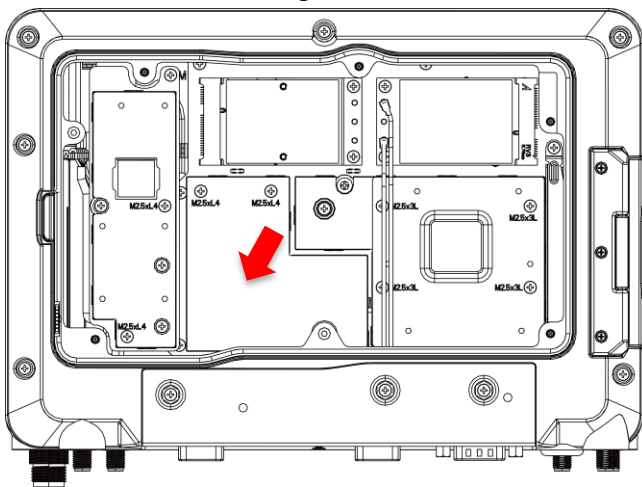

6. Locate the mSATA module slot; see the following image.

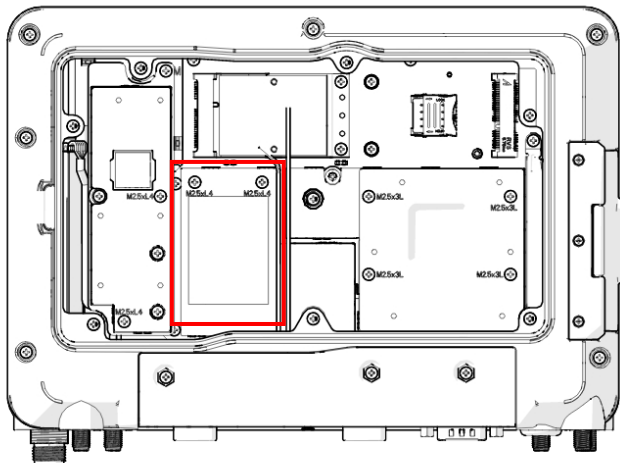

7. Insert the mSATA module into the slot and then fasten the screws or loosen the screws to remove the module.
8. Replace the service cover.

# Installing/Removing the Wi-Fi Module

MT7000 supports Mini PCIe slot in full size for Wi-Fi radio card installation; it includes PCIe and USB signal for Wi-Fi and Bluetooth combo card. The Wi-Fi module is pre-installed when you order the MT7000. To install or remove the Wi-Fi module, please follow the guidelines below.



- \* Please make sure that the device is completely powered off and make sure the power status LED light is off when removing Wi-Fi module.
- \* Need to affix the thermal pad on the module

1. Shut down the system properly and disconnect the device from all power sources.
2. Un-mount the device from the mounting apparatus; make sure that the display surface is protected.
3. Open the service cover, locate the mini PCIe slot, and see the following image. (Note: The factory default only supports full size mini PCIe slot, you must install an half-size mini PCIe card adapter for an half size mini PCIe slot).

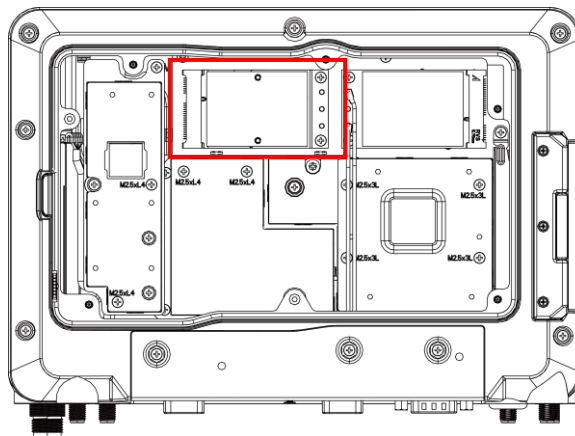

Full size Mini PCIe Card

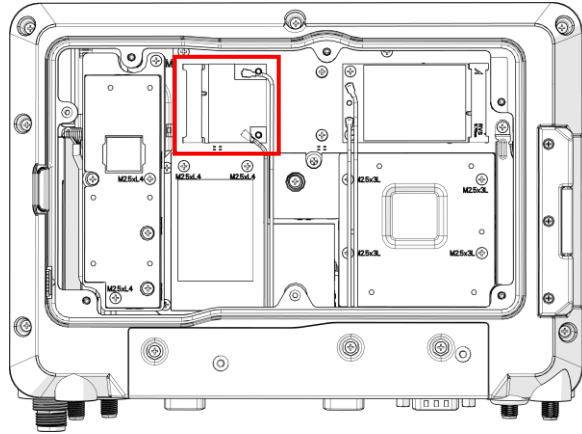

#### Half-size Mini PCIe Card

4. Fasten/Loosen the corresponding screws to install/remove the card.

Note: If you are installing the Wi-Fi module, after fastening the screws, connect the internal antenna cables to the card. If you are removing the Wi-Fi module, before loosening the screws, disconnect the internal antenna cable from the card.

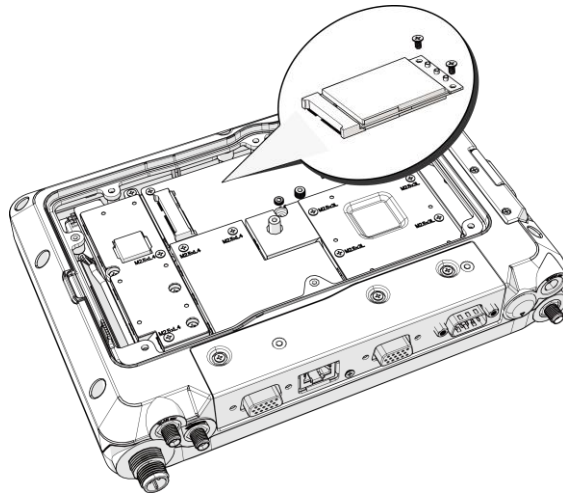

5. Affix the thermal pad on the module
6. Replace the service cover.



**Please make sure that the device is completely powered off and make sure the power status LED light is off when removing Wi-Fi module.**

# Installing/Removing the SIM card

The device provides dual micro SIM slots for cellular and wireless connection. One is inside and under the WWAN module and the other is accessible from external SIM cover.

You can either Install SIM card in internal or external SIM slot and this selection can be done via SIM slot assignment in DashON. The factory default is the external SIM slot. Please see the following guidelines to install or remove the SIM card.



**Please make sure that the device is completely powered off and make sure the power status LED light is off when installing/removing the internal SIM card.**

## Internal SIM slot

1. Shut down the system properly and disconnect the device from all power sources.
2. Un-mount the device from the mounting apparatus; make sure that the display surface is protected.
3. Remove the screws securing the cover and remove the cover.
4. Once the service cover is removed, you can see the Mini SIM card slot.

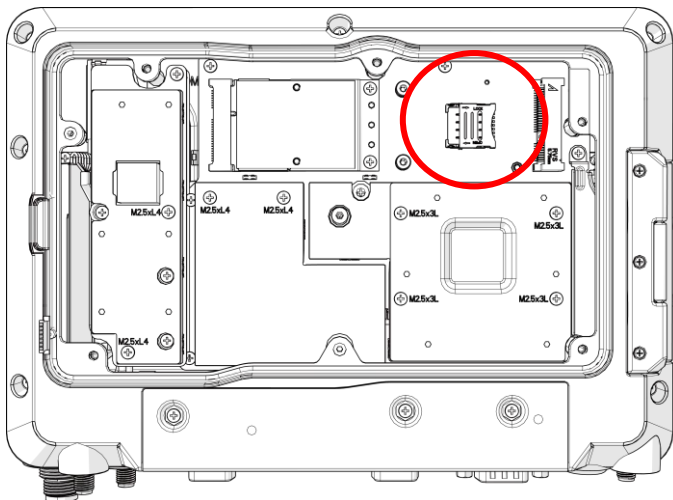

5. To release the SIM card holder, slightly lift the front edge of the cover on the card holder and slide it backwards. Open the cover.

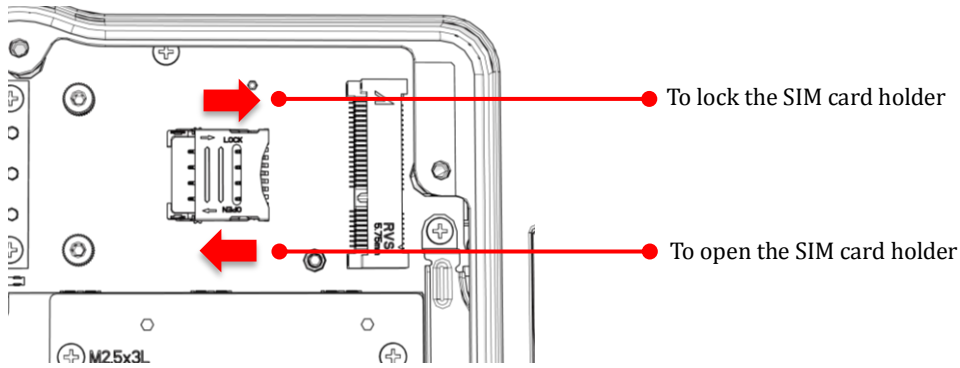

6. Turn your SIM card to the angled corner of your SIM card to match the angled corner of the SIM card holder.

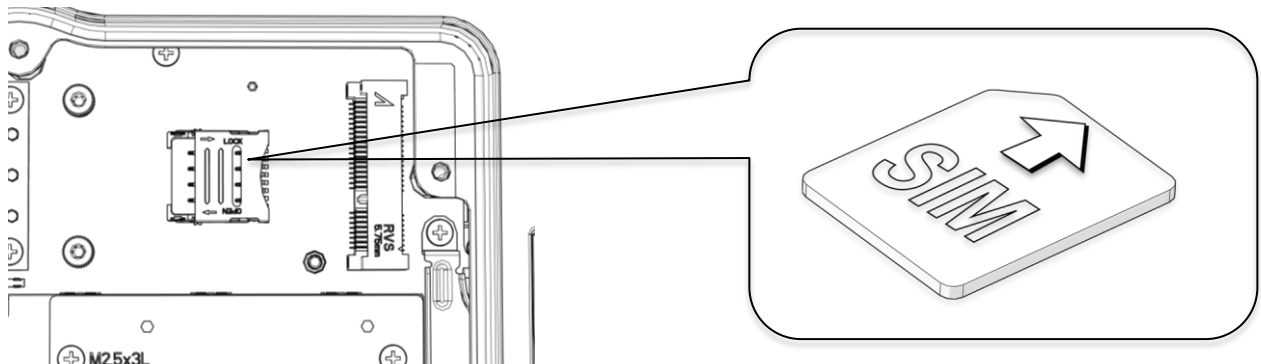

7. Insert the SIM card into the SIM card holder.
8. Close the cover of the SIM card holder.

## External SIM slot

1. Shut down the system properly and disconnect the device from all power sources.
2. Open the side cover; you can see the Mini SIM card and SD card slot.

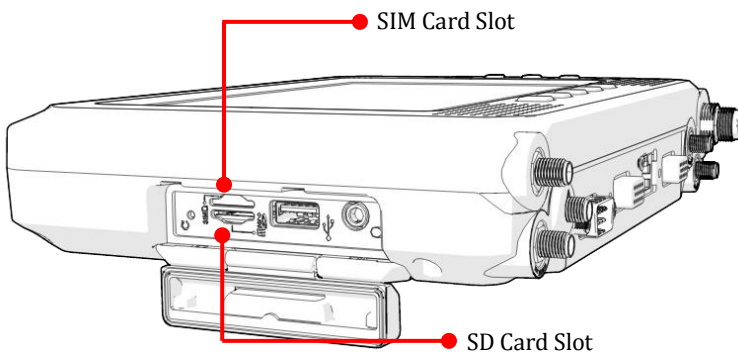

3. Insert your SIM card. Make sure the angled corner of the card is positioned correctly.

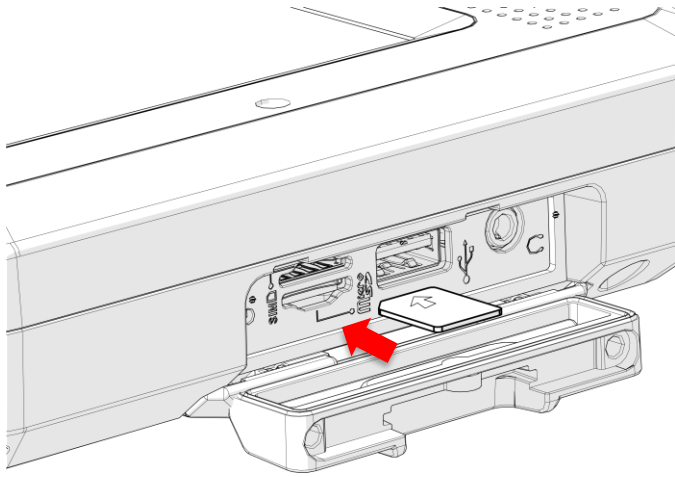

# Installing/Removing the WWAN module

WWAN card slot is also located on the rear side; it is next to the Wi-Fi module. Please read through the following introduction to install or remove the module

1. Power down the device and disconnect it from all the power sources.
2. Un-mount the device from the mounting apparatus; make sure that the display surface is protected.
3. Open the service cover; locate the WWAN module slot on the MT7000.



**\* Please make sure that the device is completely powered off and make sure the power status LED light is off when removing WWAN module.**

**\* Need to add thermal pad between WWAN module and service door for thermal dissipation. Please contact your local representative for ordering information**

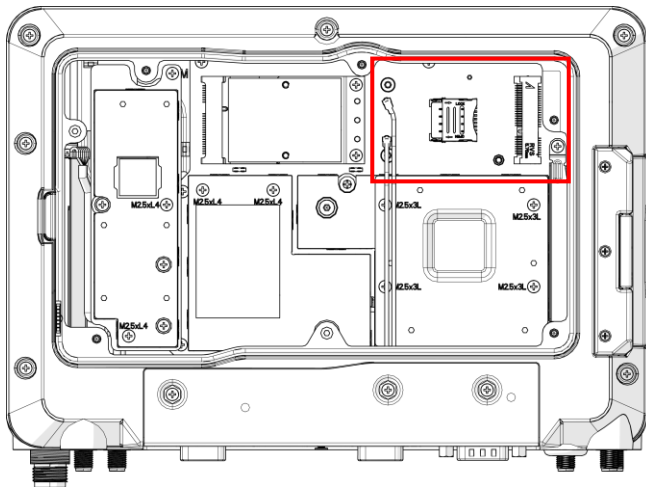

4. Install or remove the module.

## Optional WWAN Module Installation

If you wish to install optional mini WWAN module please follow the instructions below:

1. Please turn over the mini WWAN module and lock it according to the position of the extension bracket (Note: Please make sure to lock the WWAN module on the back side).



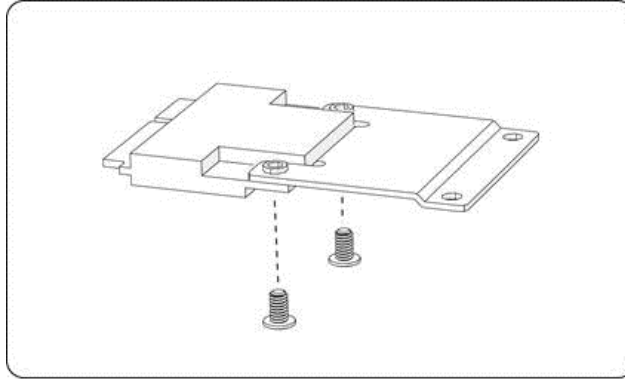

2. Please turn over the mini WWAN module on the front side (along with the extension bracket) and lock it onto MT7000 accordingly.

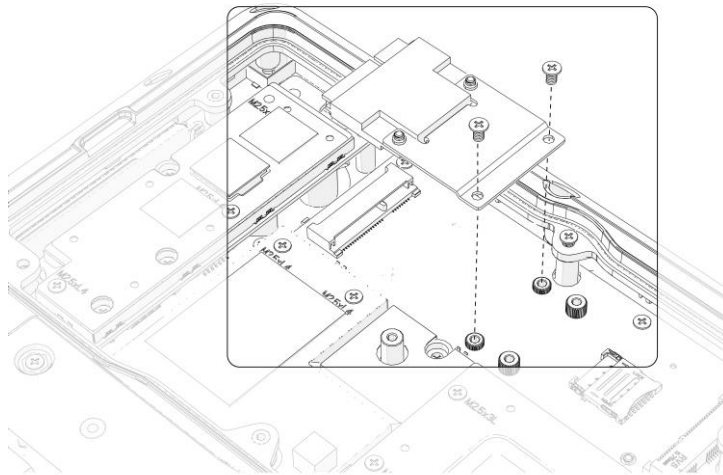

3. Please attach the WWAN/WLAN Antennas to the WWAN module.

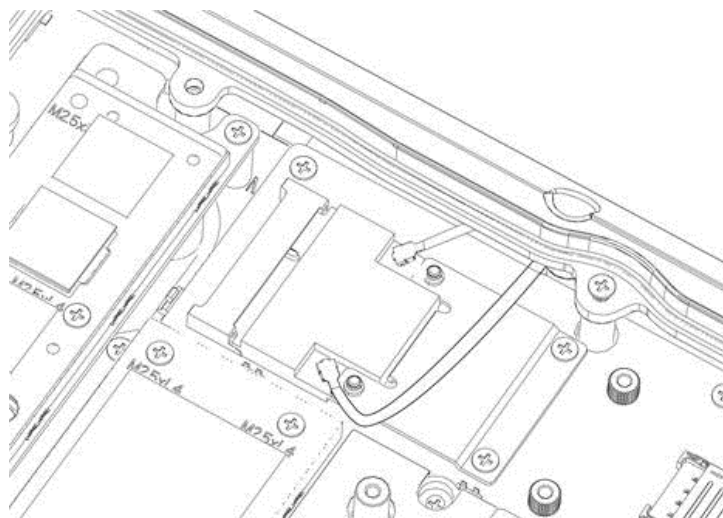

# Installing WWAN/WLAN Antennas

After you installed the WWAN module, you need to connect the antenna for use. Please note MT7000 supports internal (optional) or external WWAN antenna. If you would like to use the internal or external WWAN antenna, you need to manually disable either one of them. The following section will guide you through how to change and use your internal/ external antenna.



Please make sure that the device is completely powered off and make sure the power status LED light is off when installing or removing the WWAN/WLAN Antennas.

## Internal Antennas

1. Locate the internal antenna cable.
2. Connect the black cable to the connector labeled **MAIN**, and connect the grey cable to the connector labeled **AUX**.

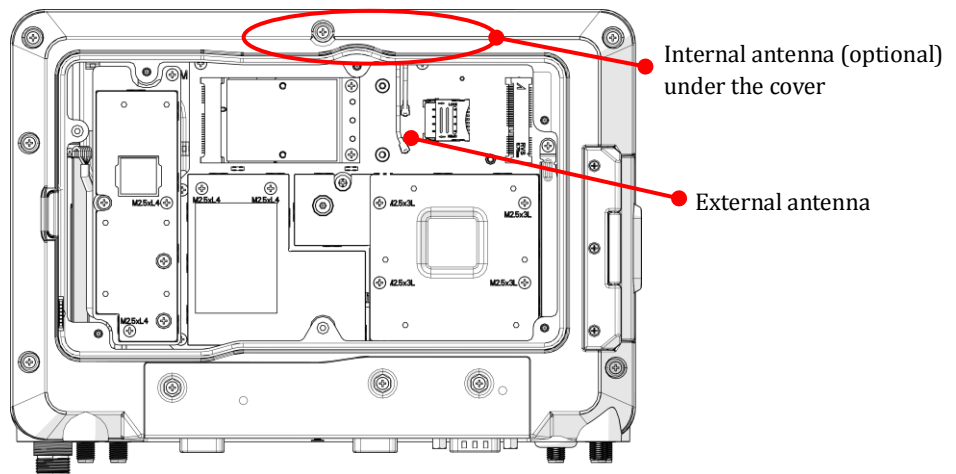

## External Antenna

1. Locate the external antenna cable.
2. Use external antenna cable to connect the black cable to the connector labeled **MAIN** and the grey cable to the connector labeled **AUX**.

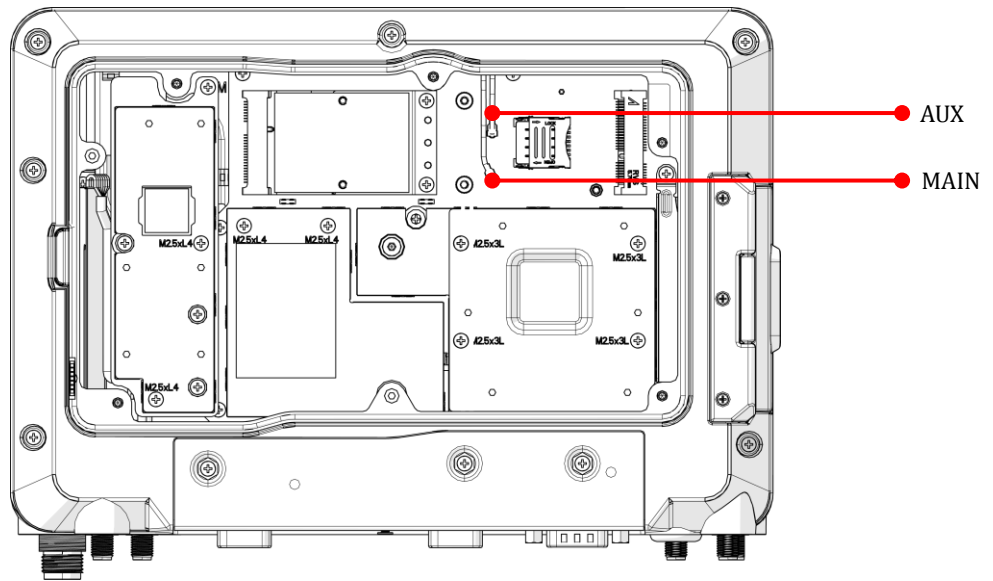

# Chapter 3. Hardware Mounting

The MT7000 supports a standard VESA version MIS-D, 75, C (75mm distance quadrate order, M5 thread, deepness 6mm) through the four drill holes on the back side of the device.

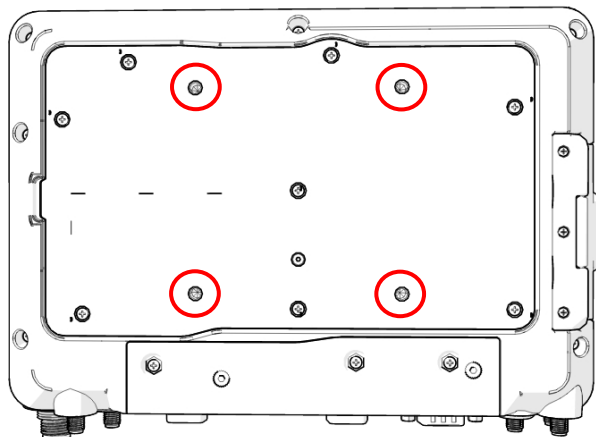

*Notes: To prevent any damage or injury, make sure the mounting bracket is securely attached.*

# Chapter 4. Start up

## Powering the System

### Installation Instructions

Fuses are required in connecting the power cable and battery in series and add 3A fuse in ACC/ignition line to avoid the risks of wire damage and vehicle burning.

Notes:

5A for 24VDC power input

10A for 12VDC power input

Please refer to the diagram below for MT7000 installation.

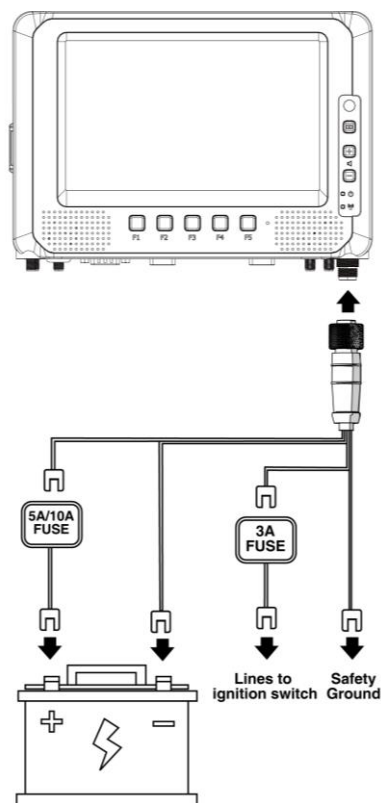

## Connector Power

MT7000 allows a wide range of DC power input from 9~36V via a 3-pin circular power cord. There are two options to start up the MT7000 via car power cable or external power adapter. Here is the 3-pin circular power cord.

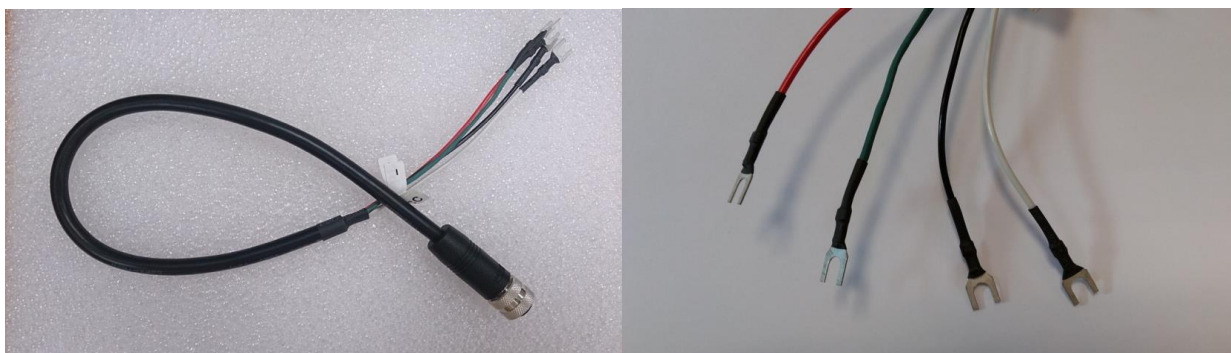

1. Use only power cables verified and supplied by RuggON to meet the specific requirements for voltage, current, low-temperature flexibility, UV resistance, oil resistance, etc.
2. Do not bend or kink the power supply cables and make sure they are securely protected against crushing and abrading.
3. Make sure power cables are correctly connected to the safety ground
4. Directly connect the power cable to vehicle battery through appropriate fuse instead of sharing any power supply lines of other equipment to avoid interference.
5. To compensate the voltage drop of the power supply cable, make sure that it is left with adequate cross-section area for sufficient ampacity.

## The wire definition

Wire Color	Description
RED	V+
BLACK	V-
GREEN	Chassis Ground
WHITE	ACC/ Ignition

## Power source from vehicle battery

1. The bare wire lead cable allows you to directly wire 12 V or 24 V car power supply. Please follow the wire definition to connect to your power source.

Please refer to the installation diagram on p26 to install the 10A fuse between the power cable and power source.

2. Plug the power code into the power connector on the top of the arrow mark.

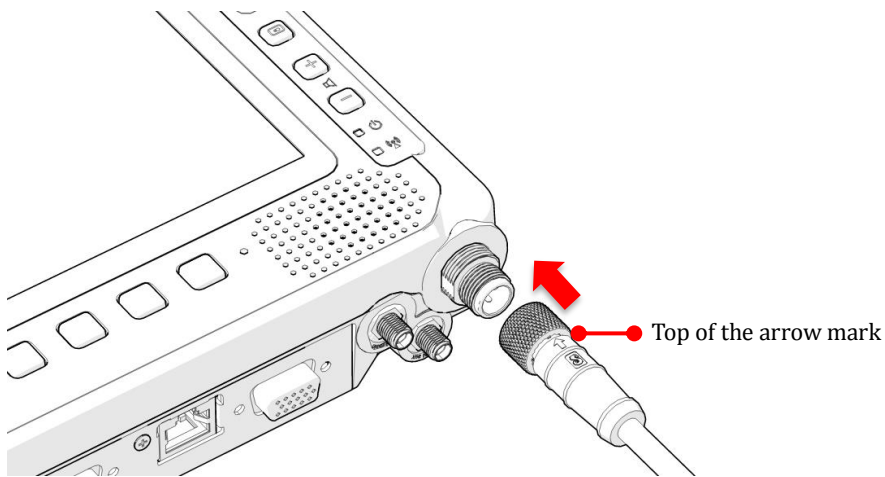

3. Twist the nut to lock the power connector to the device.

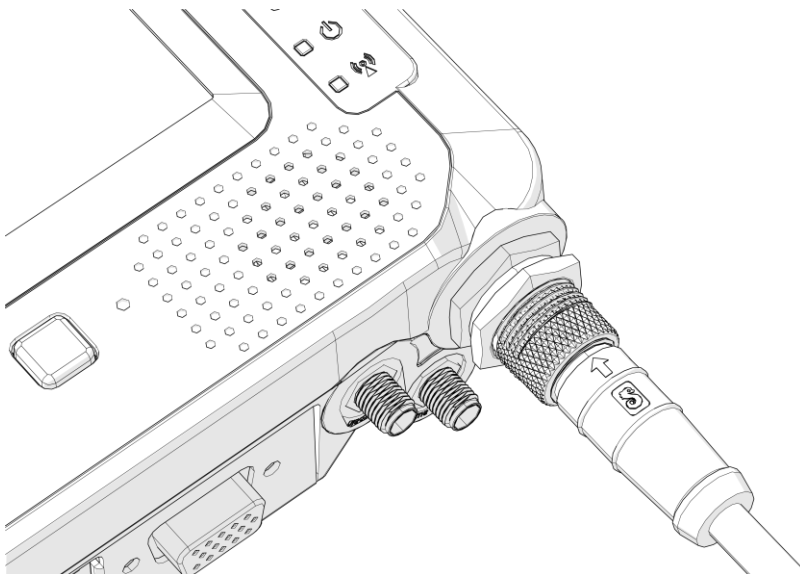

4. MT7000 will turn on automatically when the power supply is connected to the device.

## Power source from external power adapter

If your power source is from external power adapter, Please connect red (V+) and white (ACC/ Ignition) wire. ACC ignition mode is not supported in such condition.



**Make sure that all the power supplies are disconnected when you plug the power cord into the power connector.**

## Backup Battery

The purpose of internal backup of MT7000 is for graceful shutdown or sustain the system for seconds in conditional mode while the external power supply is suddenly removed or gone. This internal battery is not to sustain the system running in the normal mode. After the external power supply is gone, the system running is shift to the mode below until it complete the shutdown or the external power resume.

- (1) CPU throttling
- (2) Turn off the COM1 power output
- (3) Mute speaker

When the external power is in presence, an internal charger will automatically charge the backup battery. The ratio of the internal battery charged time against its discharged time is around 7 times. It means it takes 7 minutes to charge the battery after discharging the battery for 1 minute.

## Powering Down the System

MT7000 will be auto power off when the external power supply is not available. If you use software to power off the system, please remember to remove the power supply too; otherwise, the device will auto reboot again.



# LED Status

The LEDs on MT7000 are status indicators that show the operating status of your system. The status indicators can help pinpoint possible failed hardware components causing specific symptoms. There are two status indicators in the front panel. Refer to the description below.

LED	Status	Description
PWR	Blink Green	Power up
PWR.	Blink Yellow	Load BIOS/ boot loader
PWR	Solid Green	System ready for use
PWR	Blink Red	Abnormal vehicle battery
Comm.	Solid Green	WWAN enabled

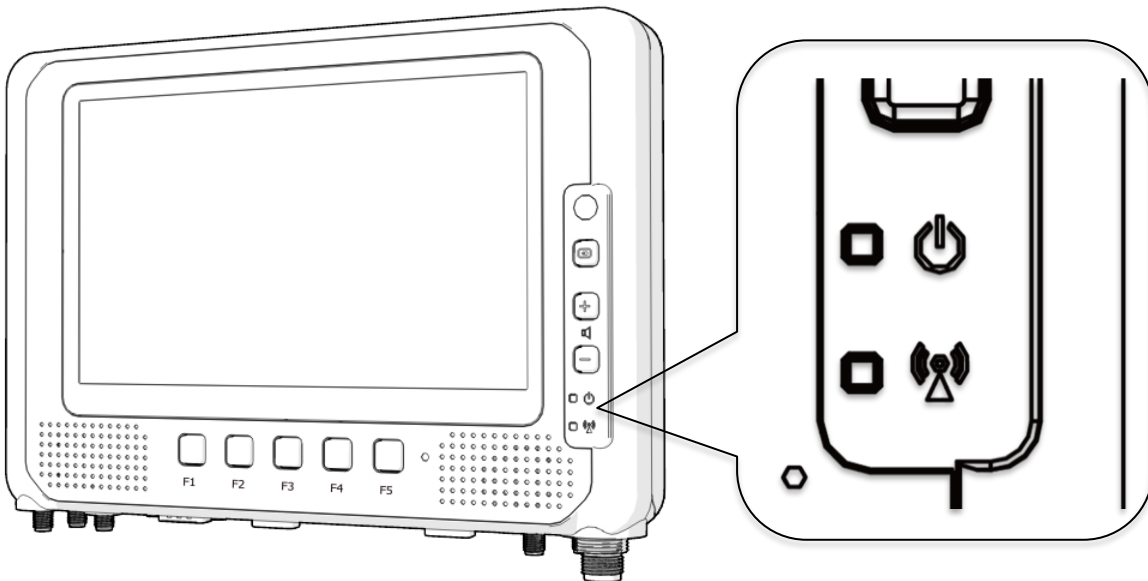

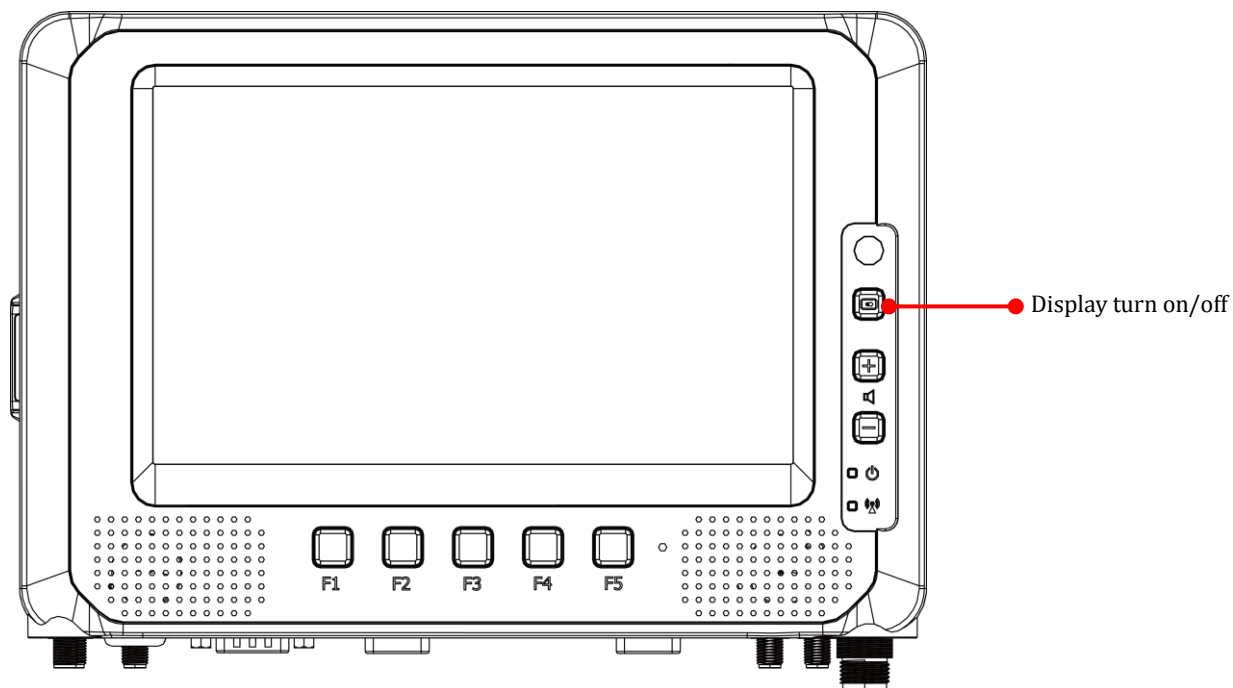

# Turn On-Screen Displays On/Off

If you do not wish information to be displayed on the screen, MT7000 allows you to turn off and on display effects in one click blue button. **It just turns the display off not making the system sleep or shut down.**



# Adjust the Speaker Volume

MT7000 provides the volume control buttons to adjust the speakers' volume; you can also control the overall level of sound using Windows. When you press the top part of the volume button, it makes the volume louder; pressing the bottom part makes the volume lower

- Press the  button to increase the volume.
- Press the  button to decrease the volume.

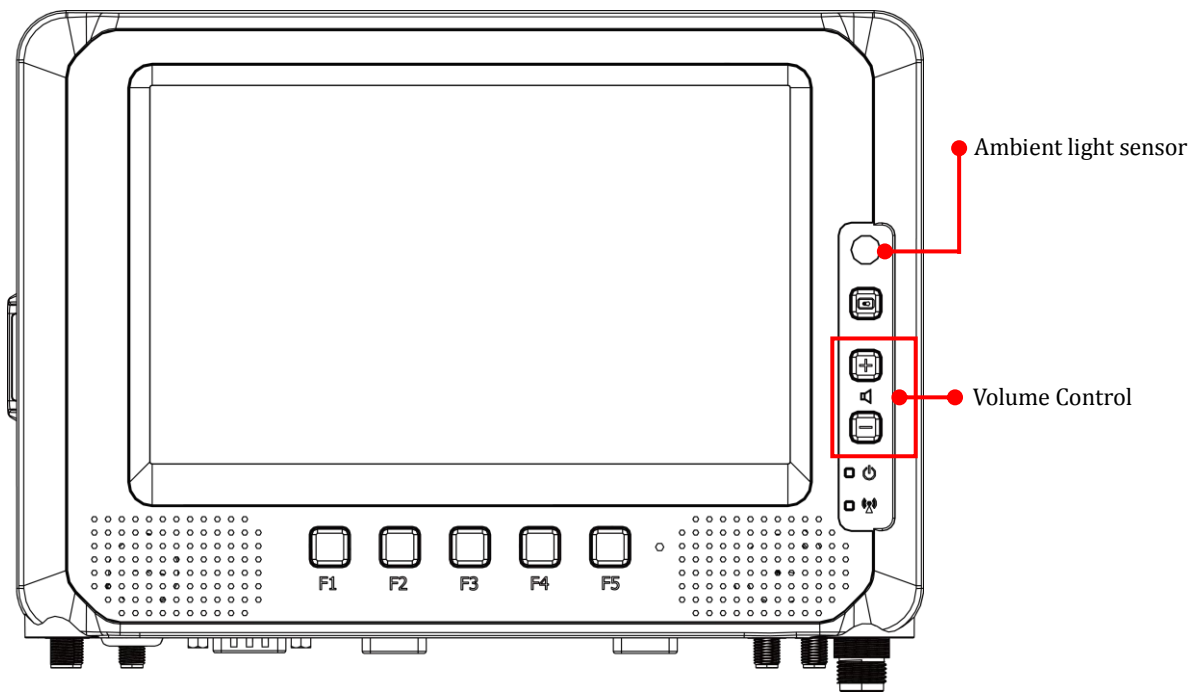

## Auto-Brightness Adjustment

When you use MT7000, you may well encounter different lighting conditions that make it difficult to see the information on screen. MT7000's built-in ambient light sensor on the front panel supports auto-dimming, which you can also disable to manually adjust the screen's brightness; this setting can be done via DashON.

## Internal Microphone

MT7000 is equipped with an internal microphone, so you don't need an external one. In addition to the built-in speaker and microphones, you can plug external headsets in the audio jack.

## Programmable Buttons

MT7000 provides default commands for five programmable buttons. You can configure the programmable buttons via DashON to different commands or keyboard shortcuts to better fit your work style.

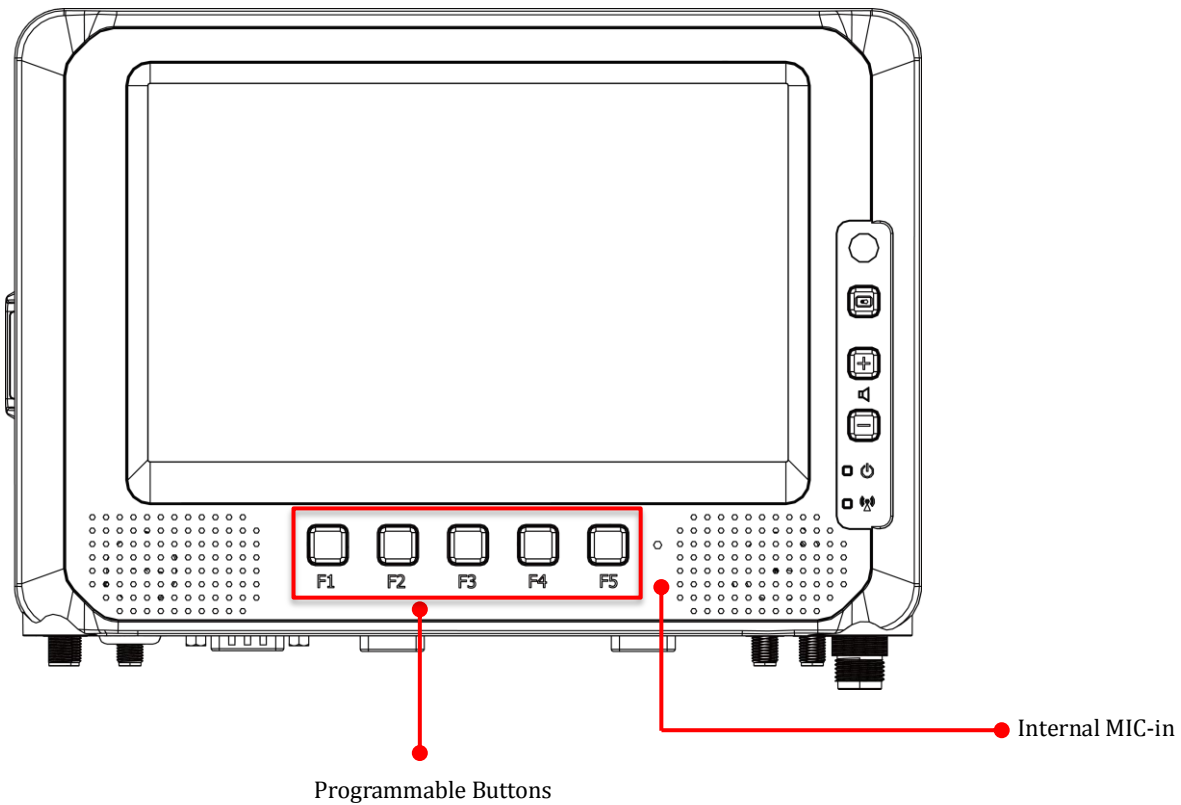

## Hardware Reset Button

If your MT7000 suddenly stops responding while in Windows, system locks up, freezes or an error occurs, MT7000 has a reset button inside the side door cover, press and release the reset button, MT7000 will reset and no settings will be changed.

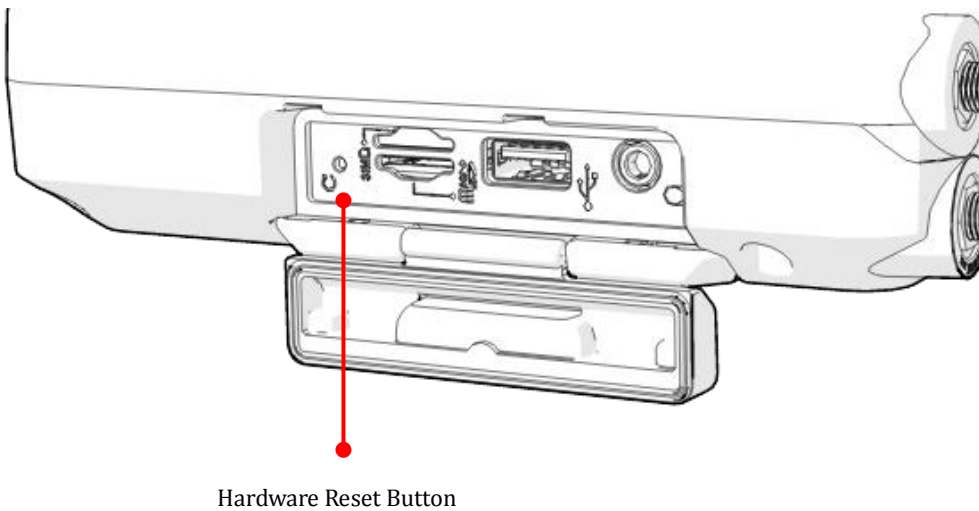

# Power Management

In addition to settings in Windows Control Panel, MT7000 also provides DashON for configuration setting which includes power management and system setup. Please refer to Chapter 6 for configuration setting in DashON.

# Chapter 5. Jumpers and Connectors

## Bottom View

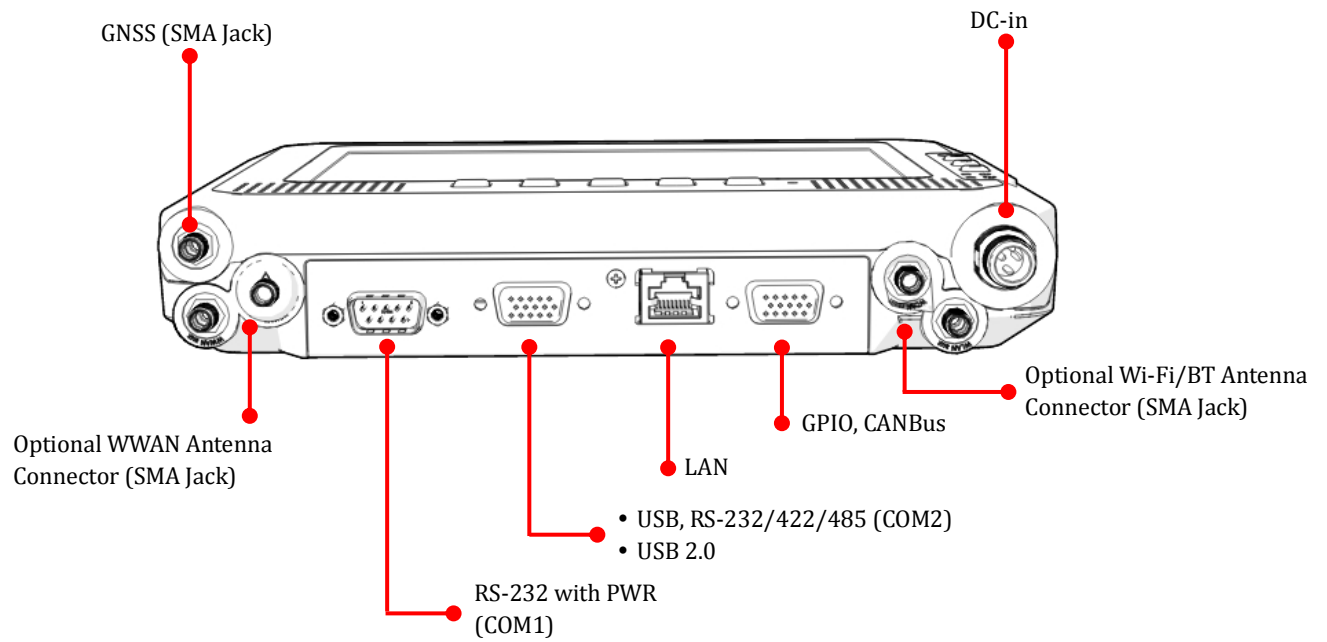

# External Connectors Pin Assignments

Use this section as a reference for the pin assignments of the various ports available on the MT7000.

## Power Connector

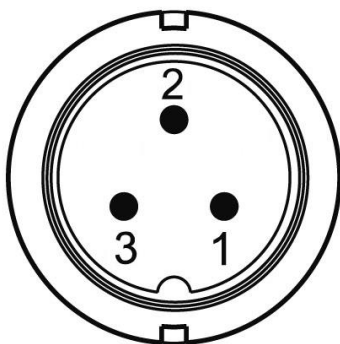

Pin	Signal
1	DC+
2	GND
3	ACC/ Ignition

Note: Please refer to section 1 in Chapter 4 for connecting the external power cable to power source.

## RS-232 Port (COM1)

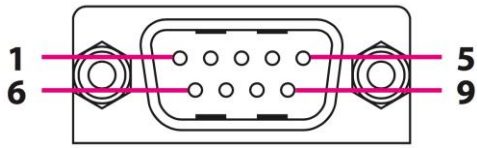

Pin	Signal	Description
1	DCD	Data carrier detect (input)
2	RXD	Receive data (input)
3	TXD	Transmit data (output)
4	DTR	Data terminal ready (output)
5	GND	Signal/power ground
6	DSR	Data set ready (input)
7	RTS	Request to send (output)
8	CTS	Clear to send (input)
9	PWR	Bar code scanner power (1 A max)



## USB and RS-232/422/485 Port (COM2)

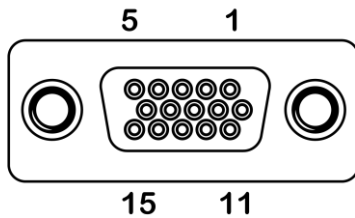

Pin	Signal
1	RS-422 TX+
2	RS-422 RX+
3	RS-485 TX+
4	RS-232 TX
5	GND
6	RS-422 TX-
7	RS-422 RX-
8	RS-485 TX-
9	USB 5V
10	RS-232 RX
11	GND
12	USB DP
13	USB DM
14	USB 5V
15	NC

We provide Y-cable with DB15 male connector which is the RS232/422/485 and USB converter. Please contact your local representative for ordering information

## RS-232/422/485 and USB Cable

This Y-cable with DB15 male connector is the RS232/422/485 and USB converter. The other end of this Y-cable contains one USB type A jack for USB2.0 and one DB9 male connector for RS232/422/485. If you like to use RS232 or RS422 or RS485, please refer to the pin definition below.



### Cable Drawing

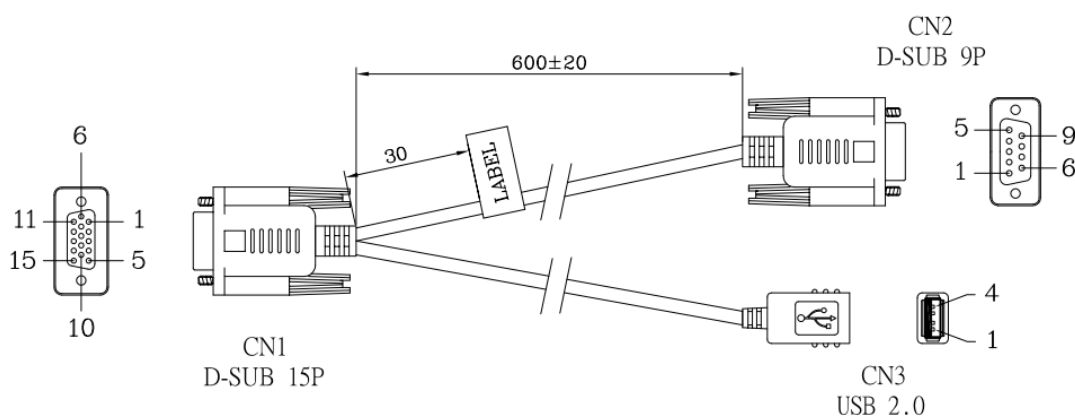

### Pin Definition of DB9 (CN2) connector:

Pin	Signal	Pin	Signal
1	RS-422 TX-	6	RS-485 TX+
2	RS-232 RX	7	RS-422 TX+
3	RS-232 TX	8	RS-422 RX-
4	RS-422 RX+	9	RS-485 TX-
5	GND		

## Digital I/O and CANbus Port

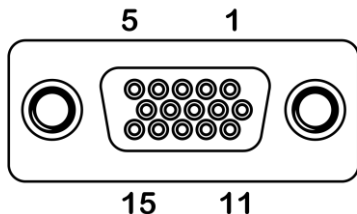

Pin	Signal	Pin	Signal
1	CAN_H	9	CARD POWER
2	N/A	10	GND
3	N/A	11	SOS
4	N/A	12	DIO_OUT1
5	N/A	13	DIO_IN1
6	CAN_L	14	DIO_IN2
7	N/A	15	DIO_OUT2
8	N/A		

We provide the DB15 male connector to multiple pins without termination cable. Please contact your local representative for ordering information

\*DI: 5V TTL Compatible Logic,

withstand max 36V input, also accept external OC/OD driving circuit.

\*DO: 5V TTL Compatible Logic, max sink 30mA while driving low,

internal pull up 5V thru 330 ohm, also accept external 4.7K ohm resistor pull to 36Vmax.

# Chapter 6. DashON Setting

You can use DashON to configure the device for your demo or test. We also provide the corresponding SDK for your application development. DashON will auto-run in background while the system turns on. This section is to brief you on what functions are included in DashON and how to set up based on Windows OS.

## 1. Device Information

It provides information of system hardware, software, and firmware version.

## 2. Vehicle Status

This section is to demo how to read the vehicle information such as vehicle battery voltage, fuel, speed and so on while connecting with vehicle SAE J1939. We use a simulator to run the demo.

## 3. Communication Setting

This is to enable/disable Wi-Fi/BT/WWAN and configure the related setting.

## 4. System Status & Setting

This section contains the major configuration of the system device. Power management, wake up event, I/O configuration, brightness and watchdog timer setting are included.

## 5. Location & Sensor

GPS configuration setting and temperature status

Double click on the DashON icon if DashON is not running in background

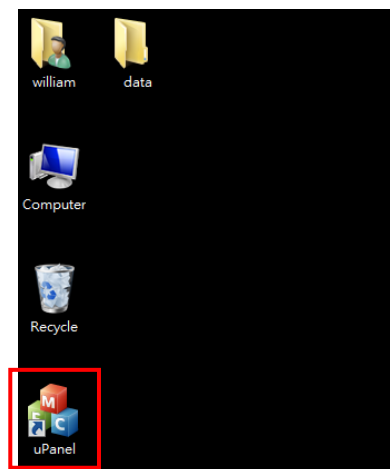

# Device Information

Click on the “Device Information” icon

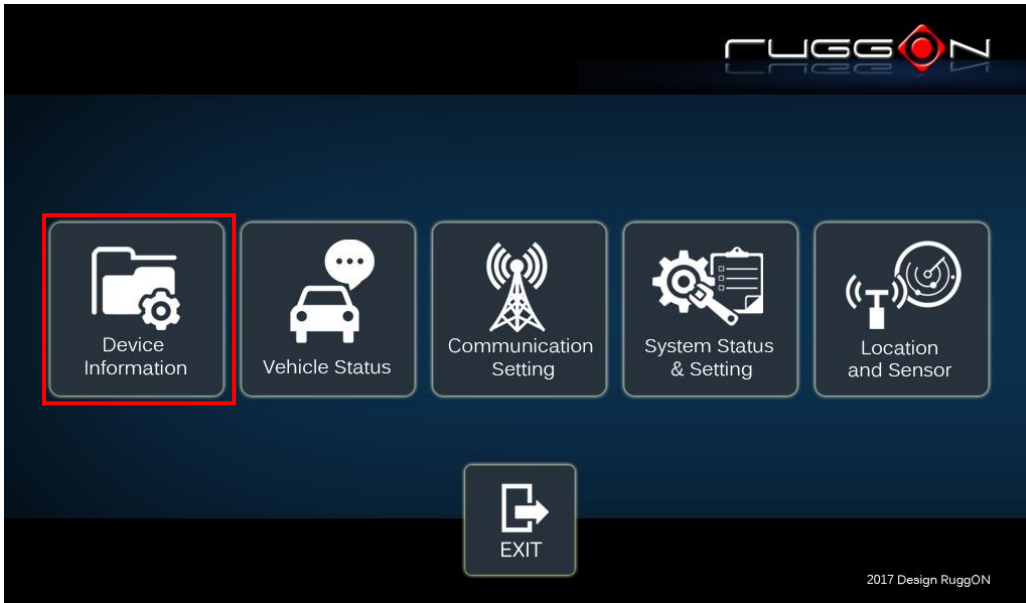

In device information, you can see the PCBA version, DashON utility version, BIOS version, EC version and system model name.

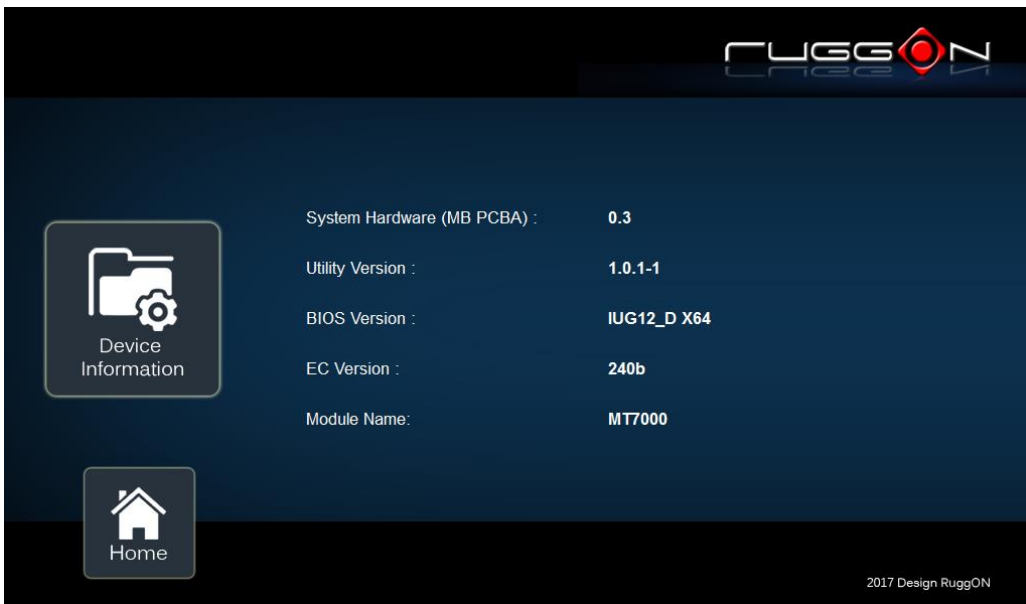

# Vehicle Status

Vehicle status shows some vehicle information from the simulator.

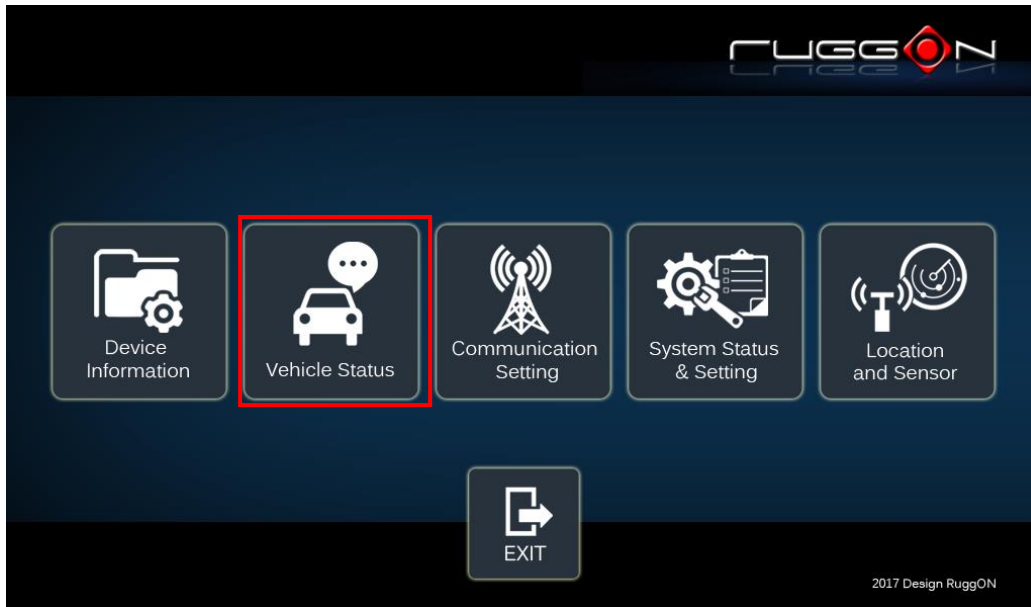

The related AT command is available upon request. Please contact local sales representatives or login to the support website.



# Communication Setting

Communication setting allows you to enable/disable Wi-Fi/WWAN/Bluetooth via DashON utility. Please click on the “Communication Setting”

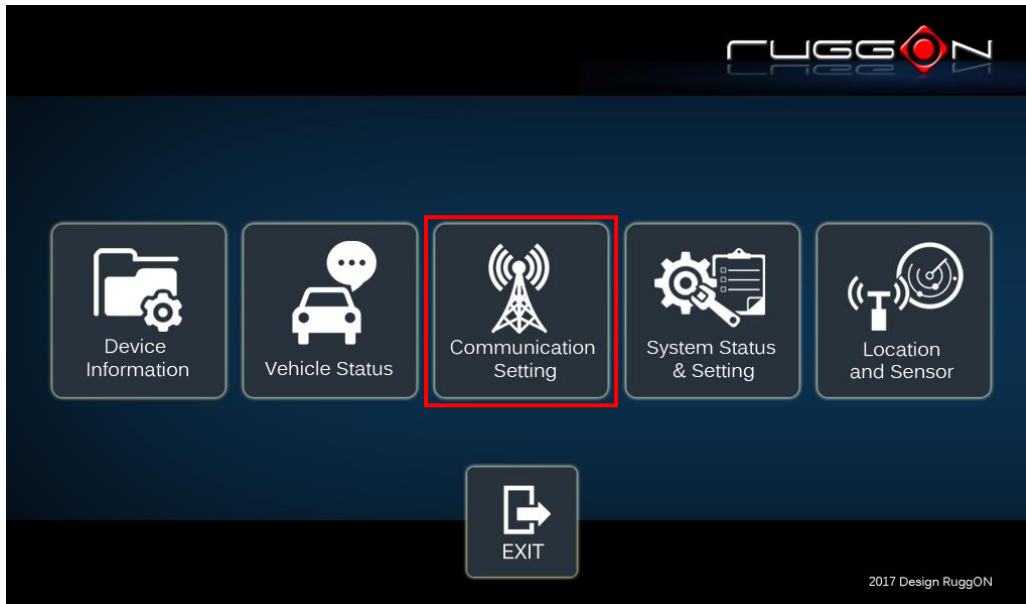

## Enable/ Disable Module

- Item 1. Click on the switch bar to power on/ off the WWAN module.
- Item 2. Click on the switch bar to **Enable/ Disable** Wi-Fi function& Bluetooth function

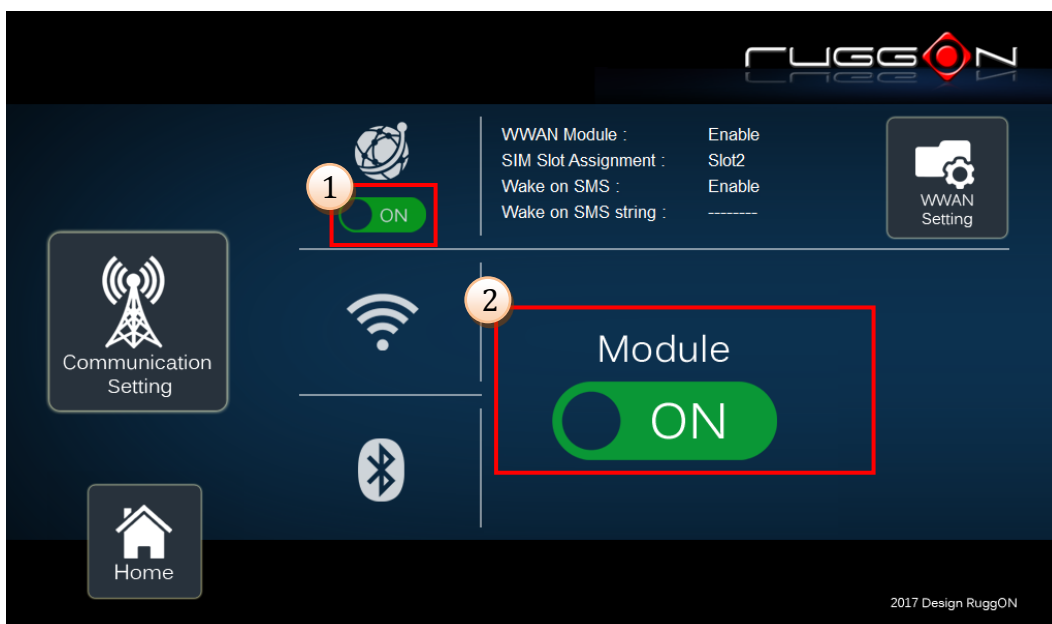

# WWAN Communication Setting

If WWAN module is present in the device, you can click on “WWAN setting” to get into the detailed setting.

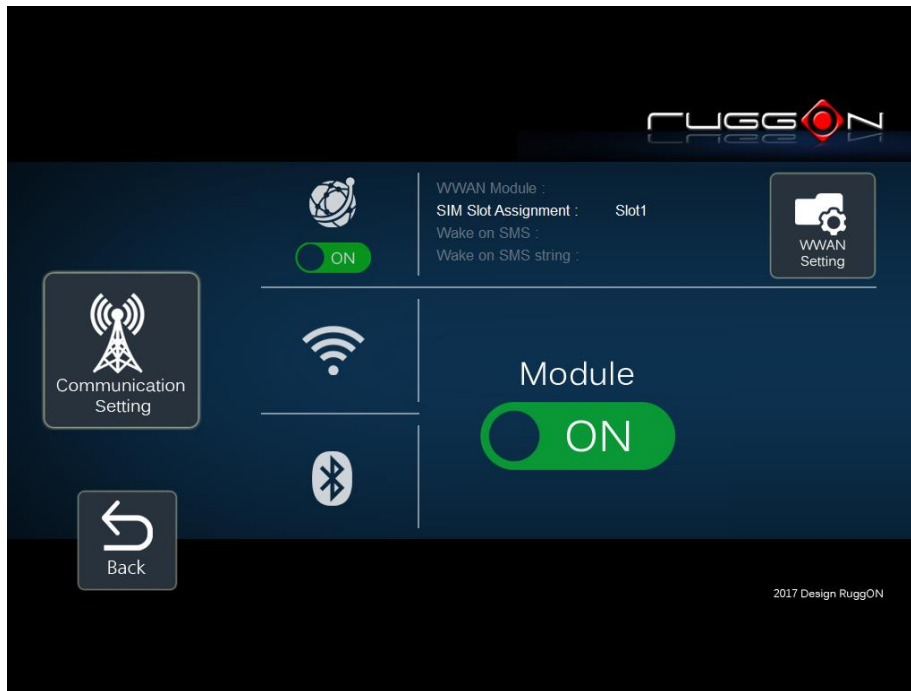

You can set the two major features including WWAN RF on/off and SIM slot selection.

1. Module RF Enable/ Disable: to enable or disable the WWAN RF transmission.
2. SIM slot assignment: This feature is only available for the device with multiple SIM slots.

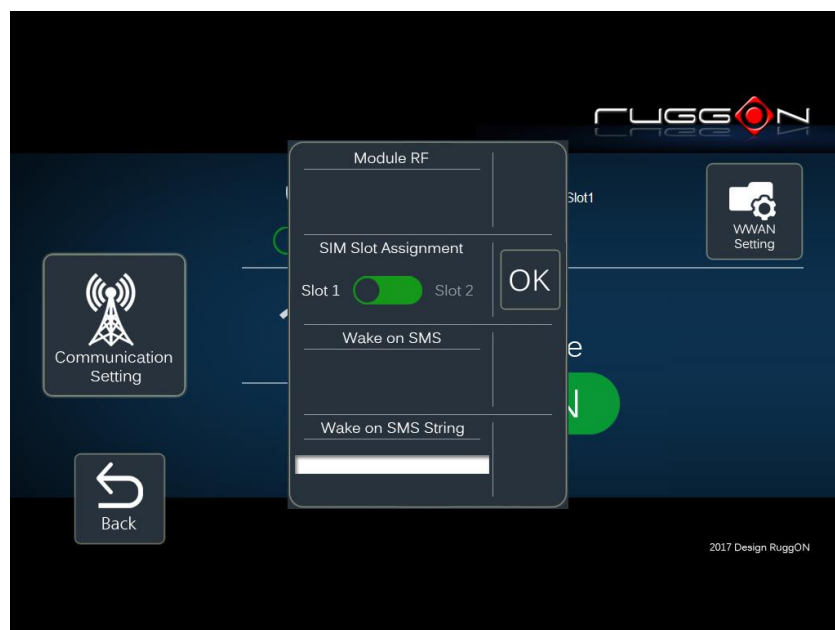



# System Status & Setting

This section is to set and read the system status. It covers power management, internal backup battery, I/O configuration, wake up event and so on.

## Power Automatic Turn Off Behavior

When the system voltage drops below the UVP or when the power cable is disconnected, UVP is triggered and shuts down the system.

With OS (Windows/Android) and DashON utility installed, the system will auto shut down in a minute. If DashON isn't installed or the OS crashed resulting in DashON not working properly, EC will forcibly power off the system in 7 minutes.

For other auto power off situation, refer to Powering down the System on p29.

## Power Management Setup



Please click on the “Power Management”

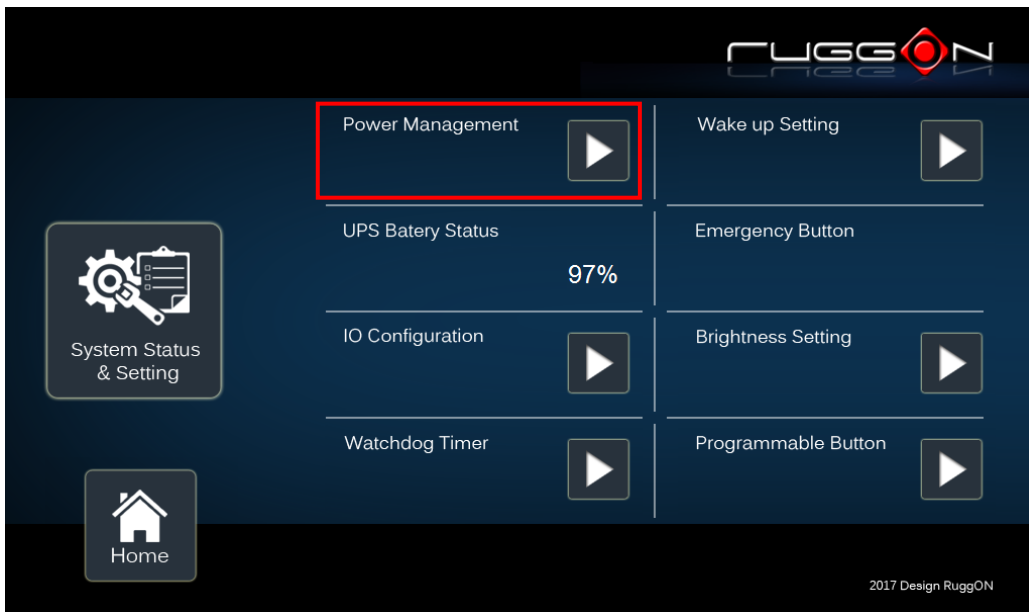

## ACC Detection Setting

In MT7000 design setting, it supports ACC sense. You can check its status from ACC status.



## Input Voltage Setting

Click on the  to select the input voltage setting.

You can select the power input voltage either 9~36V or 12V or 24V. If 9~36V is selected, it means the system can be powered on while the voltage ranges from 9~36V.

Please note if you use a 19V power adapter, the input voltage must be selected to 9~36V.

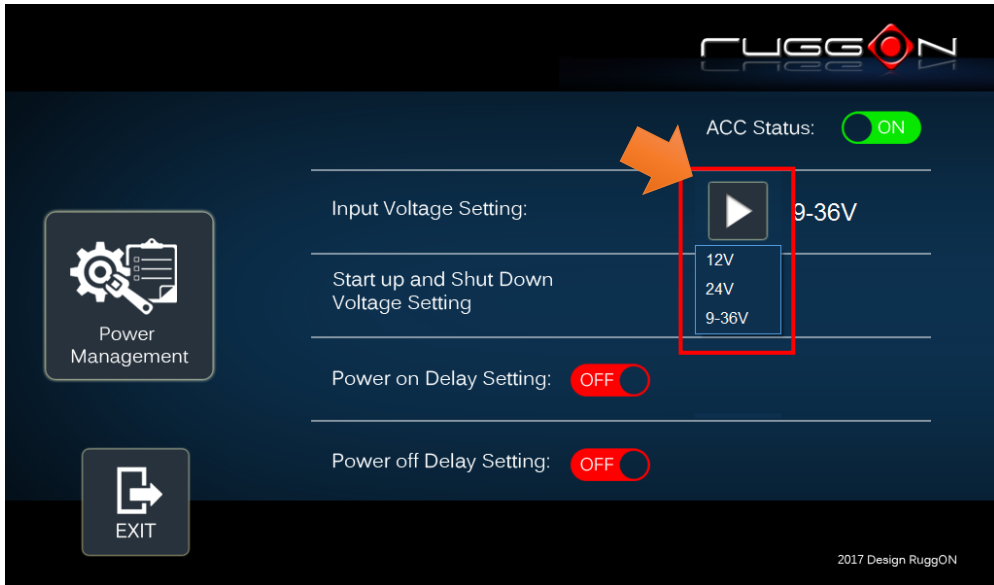

If 12V or 24V is selected, you can also select the startup and shut down voltage setting.

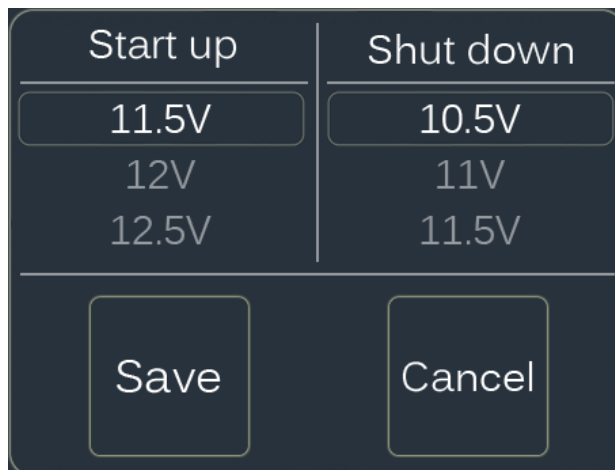
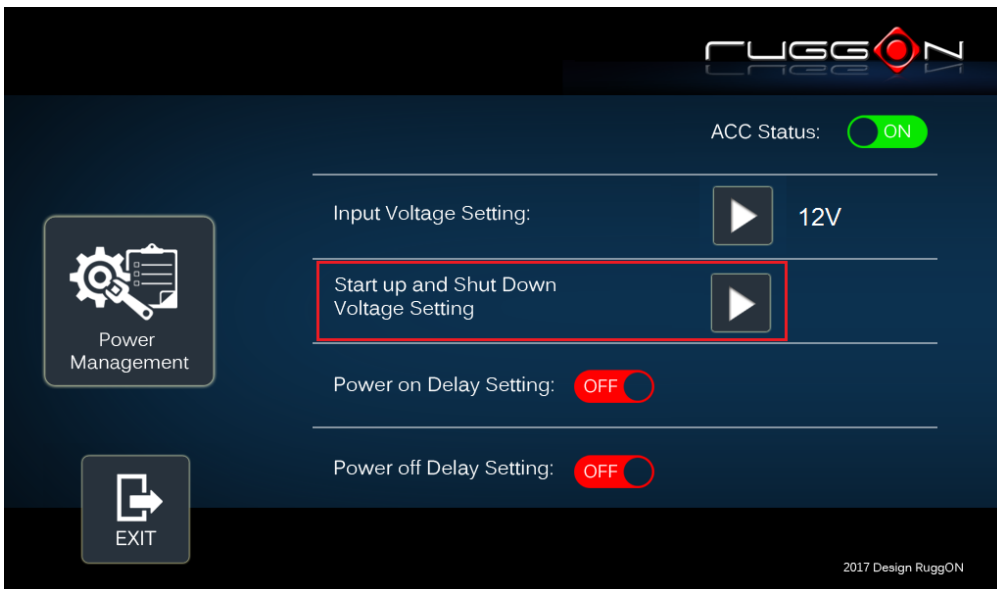



If the above selection items do not meet your demands, please contact local sales representatives.

## Power On/Off Delay Setting

Power on delay function enables you to power on the device after the ACC is on for a

specified period of time. Enabled power off delay function lets the device remains on until the ACC is off for a specified period of time.

## Power On Delay

You can set the system startup time after ACC is on.

Switch the  to , click on the , and you will see the selection list. Delay time can be set at 10sec/30sec/1min/5min/10min/30min/60min/6hr

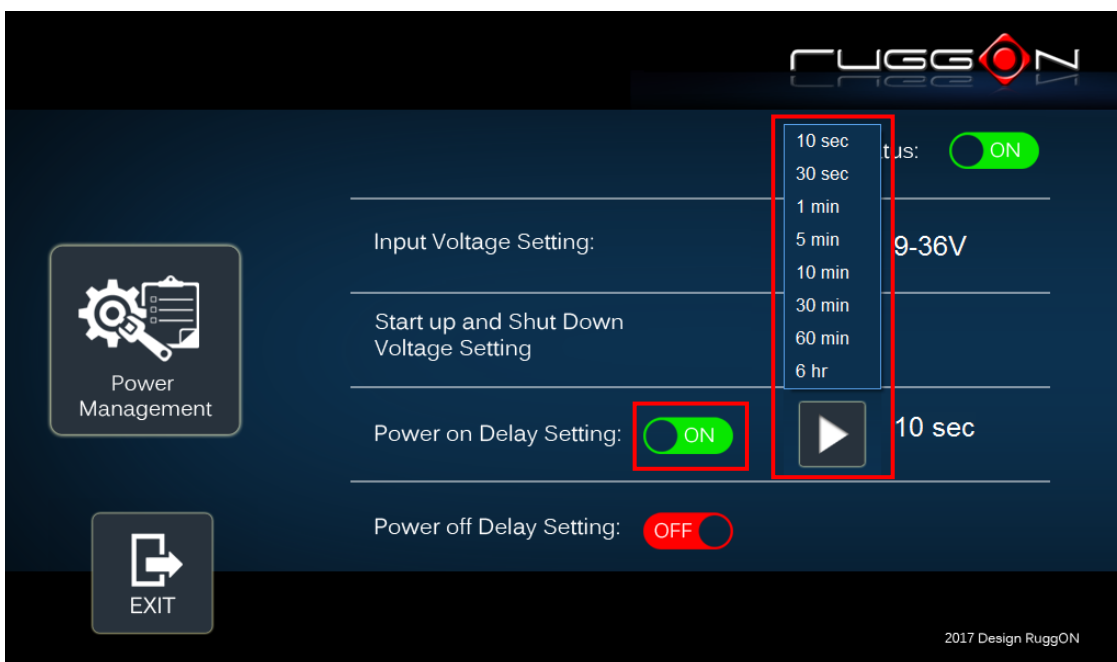

## Power Off Delay

You can set the system shut down time after ACC is off.

Same as power on delay setting process; you can also set the power off delay.

Delay time can be set at 10sec/30sec/1min/5min/10min/15min/30min/60min

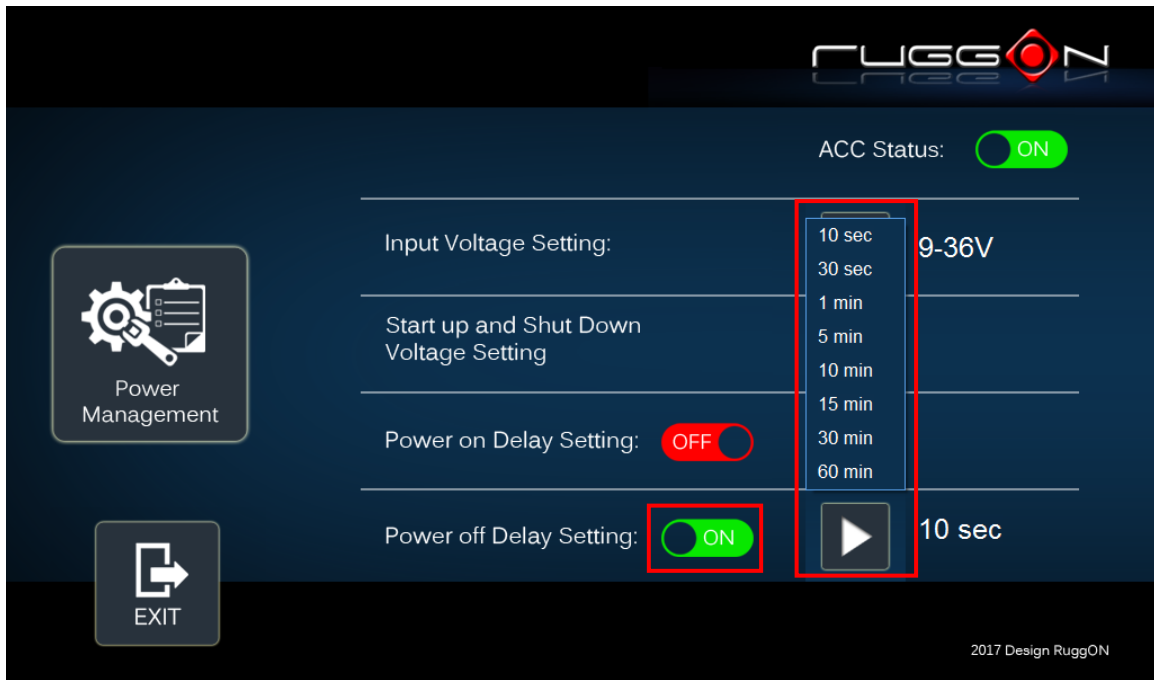

## Wake up Setting

In addition to ACC sense, two wake-up events are enabled to power up the device. They belong to RTC wake up. Here is the setting method.

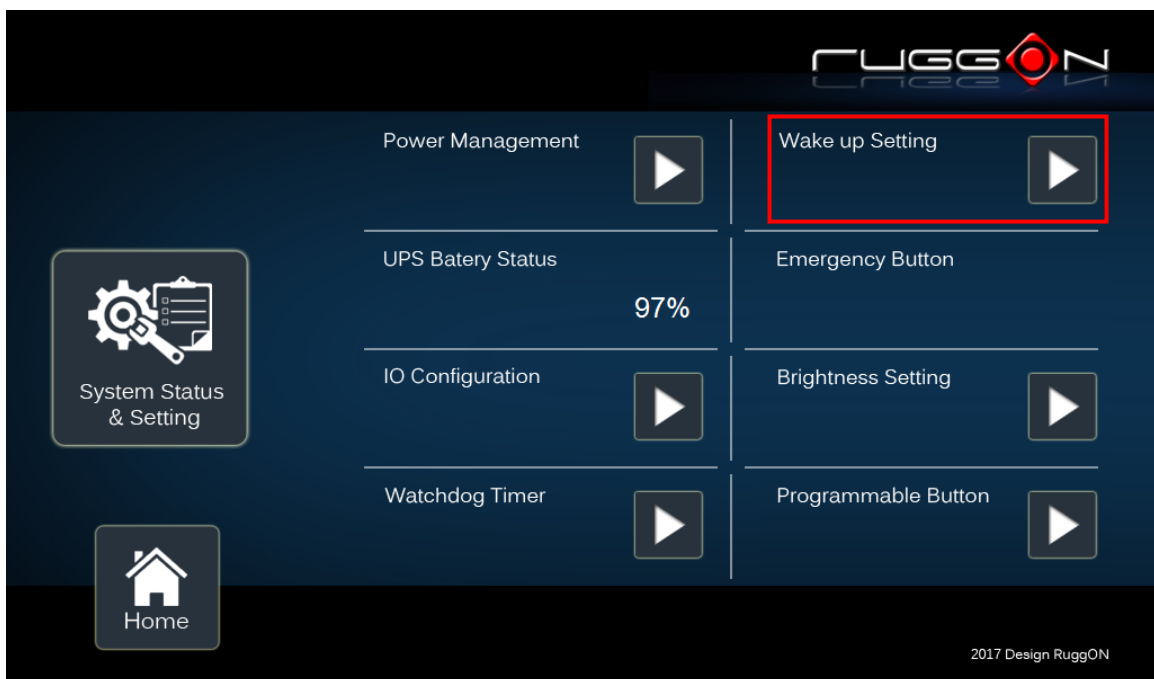

“System Status & Setting”-> “System Status & Setting” ->”Wake up Setting”

In Wake up setting, you can find “Wake on RTC” setting

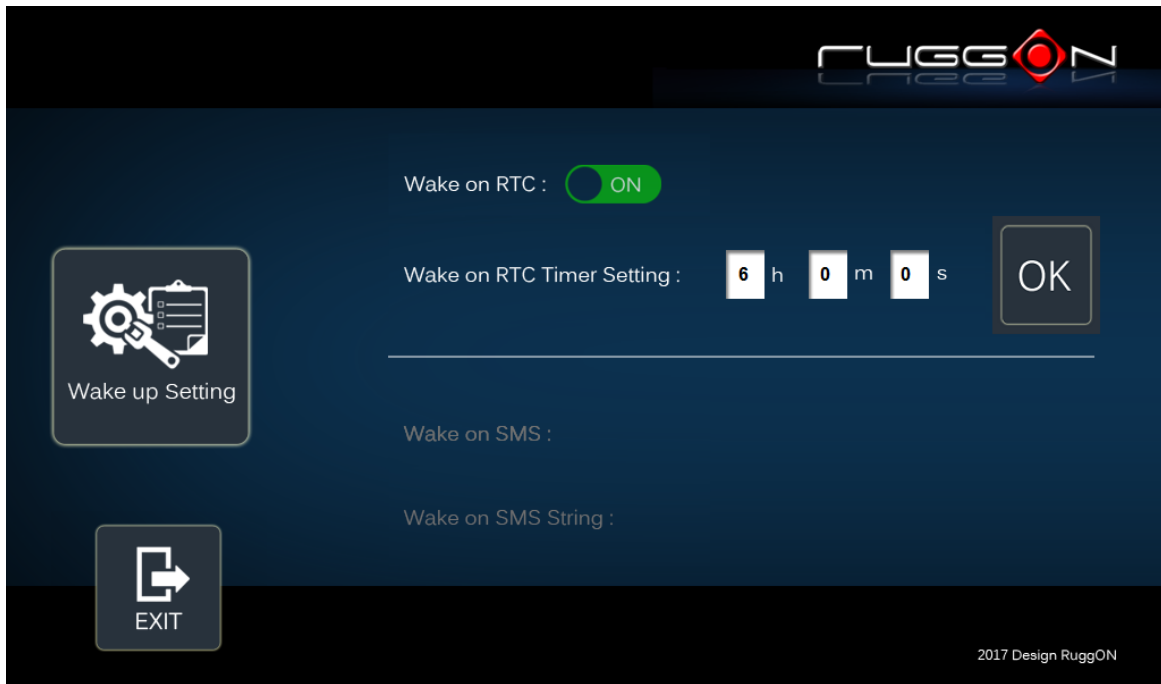



## RTC wake up setting

Click on the  to , you can find RTC timer setting to set your desired time to power up the system.

After you have finished with the setup, click on the “OK” to save the value. For example, if you set 06:00:00, it means the system will be powered up at 6 o'clock in the morning.

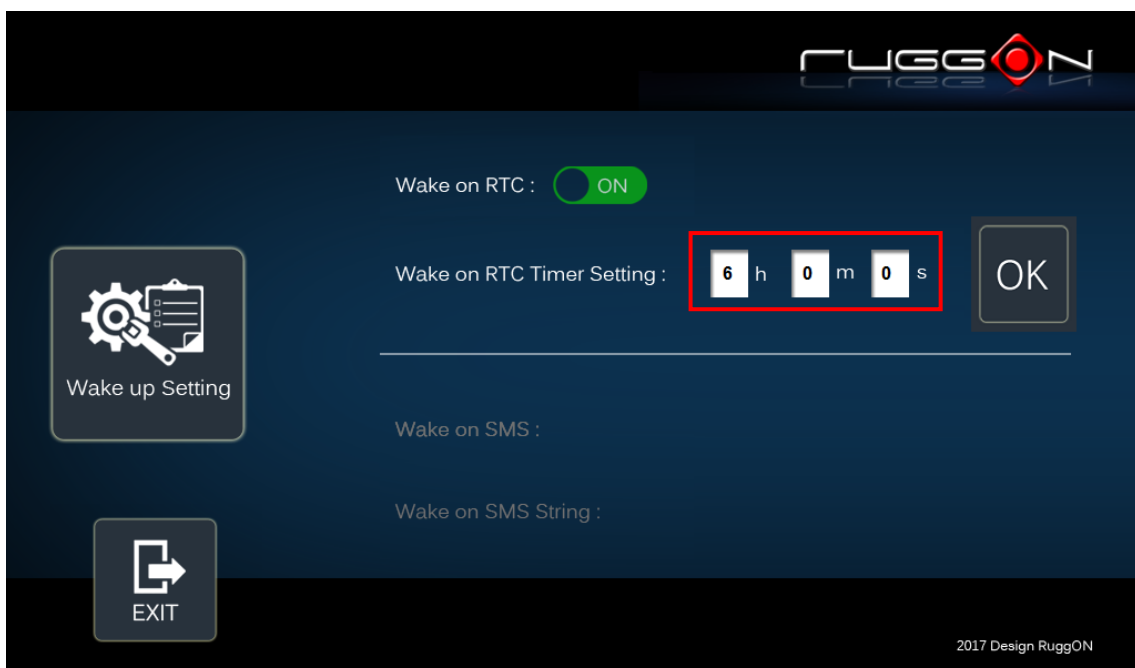

# I/O Configuration

## COM1 Setting

RS232 (COM1) supports 5V or 12V power output for users to easily connect with barcode scanner or other equipment. The maximum current is up to 500mA.

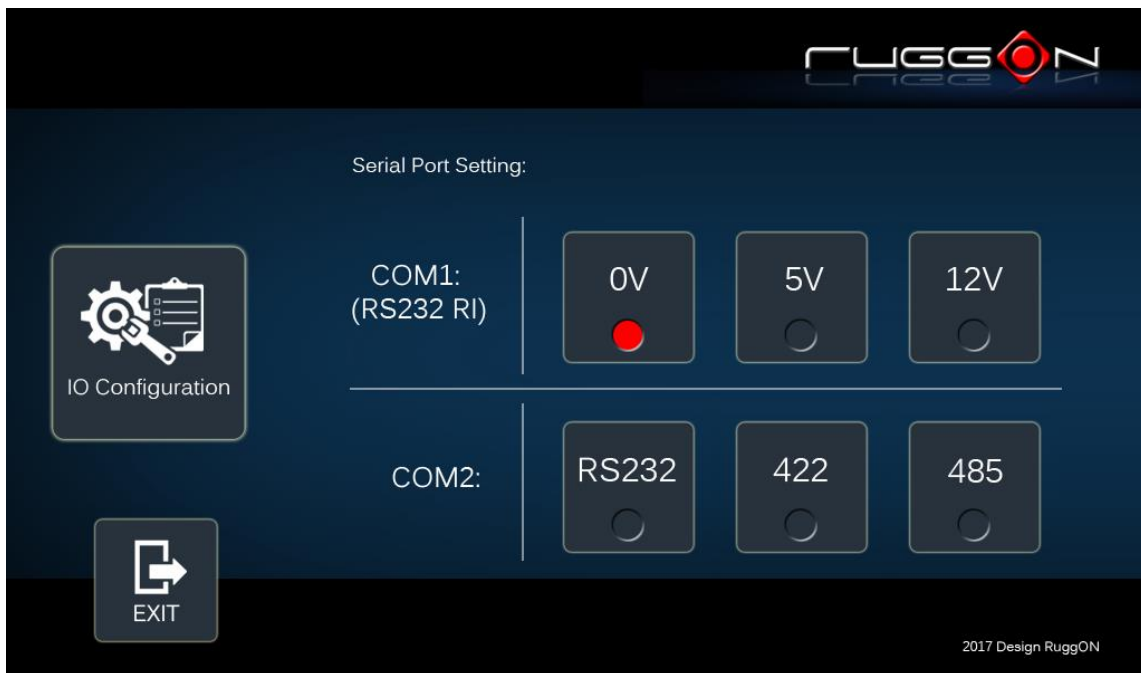

If you don't need the power output, just select 0V output to avoid the equipment damage. Please note if system power source is from backup battery (no DC input available), COM1 will stop supplying the power output.

## COM2 Setting

The COM2 includes RS-232(TX, RX), RS-422 and RS-485 signals. Please select your required items and connect the Y-cable converter to the system. Please refer to the pin out description for correct connection.

## Brightness Setting

Brightness adjustment is to optimize the operation of the backlight LEDs under a variety of daylight conditions. MT7000 supports auto-dimming and manually adjusts the brightness. If



auto-dimming is enabled, the brightness is auto adjusted along with the changes of environmental light. You can also manually change the display brightness via programmable buttons or the bar adjustment in DashON. For programmable button setting, please see “Programmable Button “section. MT7000’s display brightness is set to automatic adjustment. You can also turn off “Auto-Dimming” and drag the scroll bar to adjust display brightness.

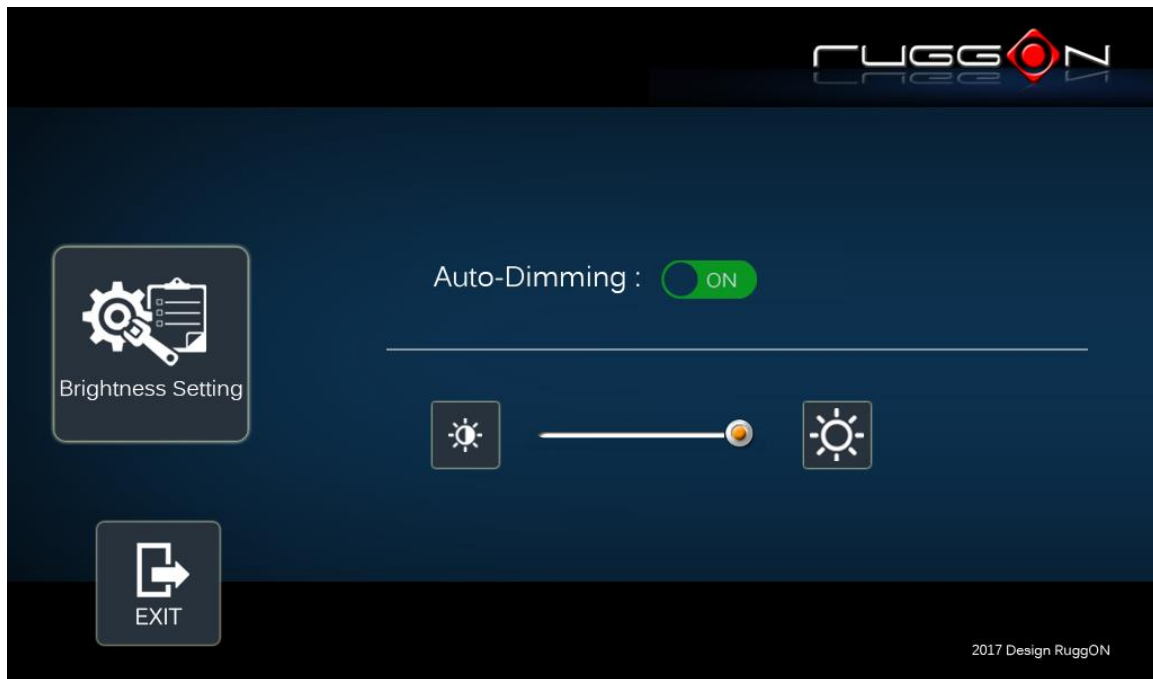

## Watchdog Timer

This section is about the timer setting of watchdog and the simulation of watchdog functions. When the system is hanging due to some reasons, you are able to reboot the system automatically after the set time frame.

Double click on the DashON icon, and then click on the 4<sup>th</sup> icon “System Status & Setting”.



Click on the “Watchdog Timer”

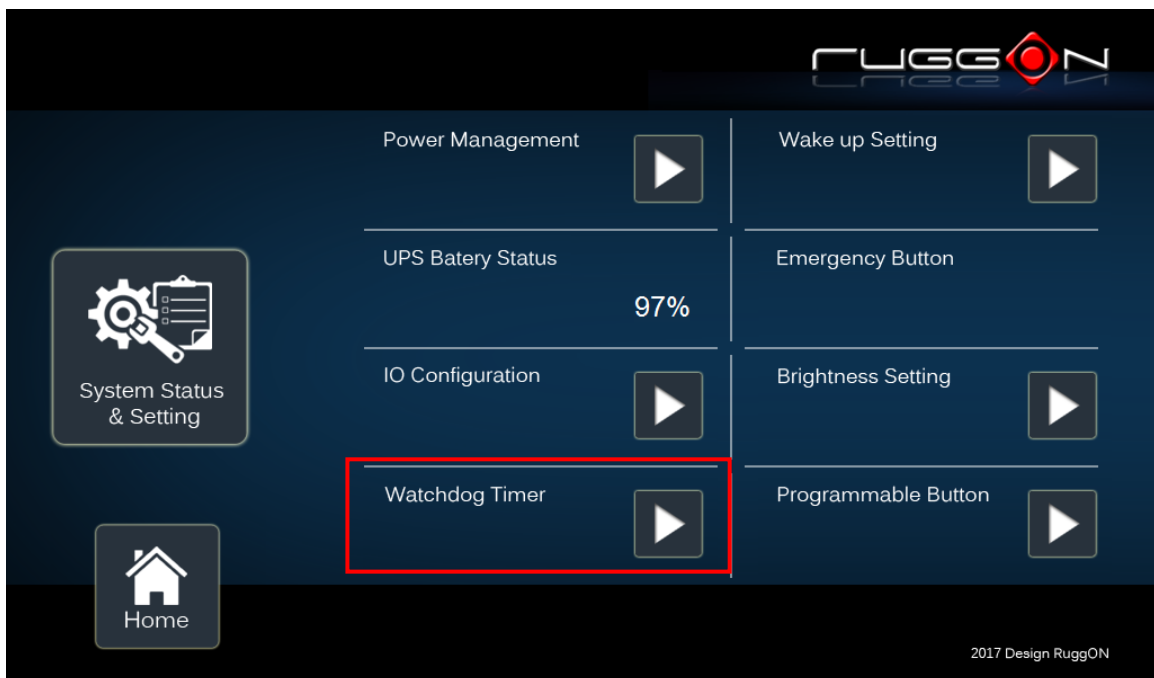

Select the timer setting.

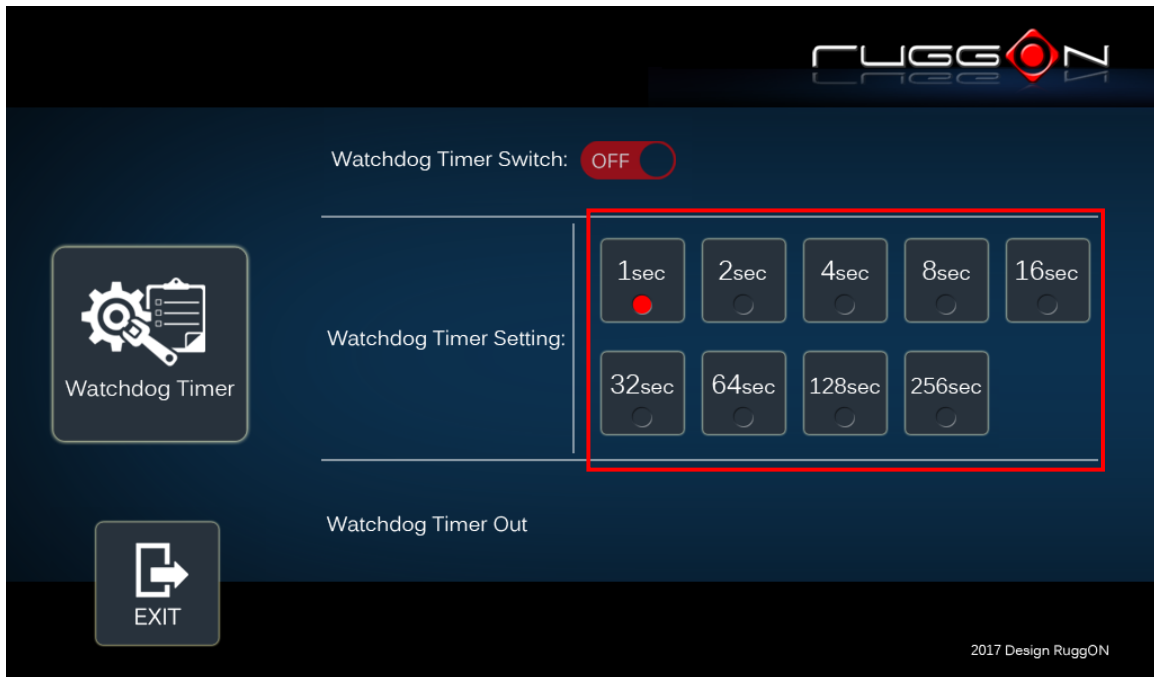

Turn on the watchdog switch.



If you'd like to test if the watchdog timer is enabled and working, please click on the "simulation" icon. The "simulation" is to simulate the system on hang and reboot it after the set time frame.

# Programmable Button

Programmable buttons can be set to different functions per user's definition.

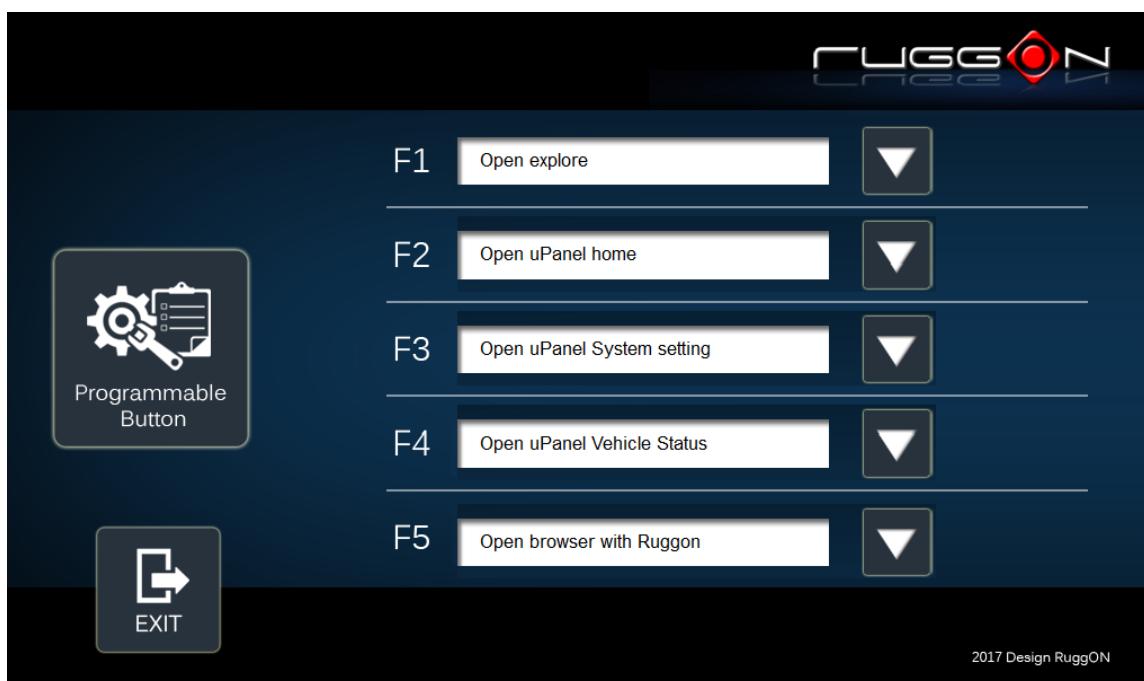

Select which function key button you want to set and then click on the  to select the function from the list.

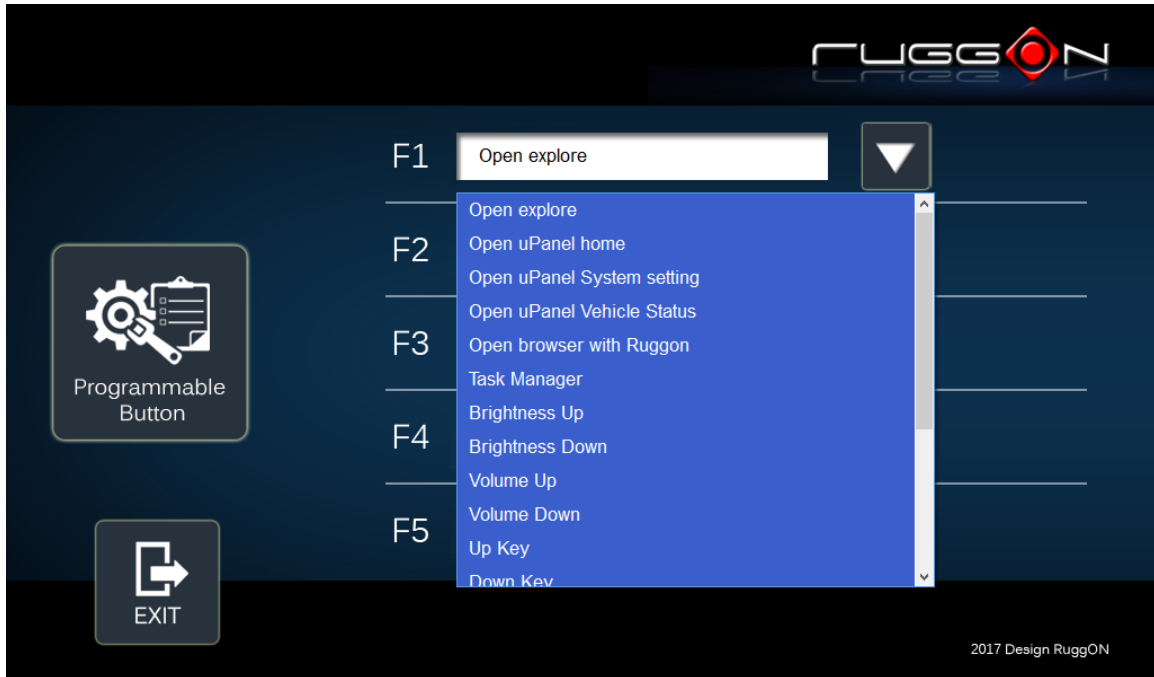

User can also define the keystrokes for function keys by selecting the “User Defined Command” from the list.

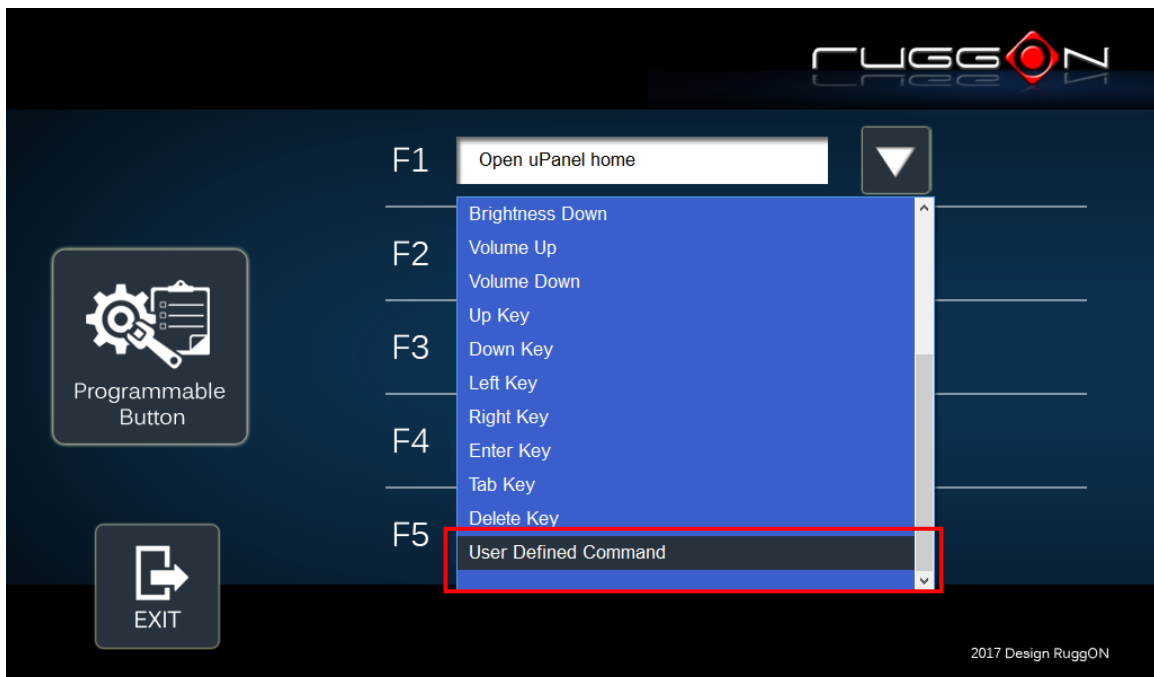

# Location and Sensor

MT7000 provides the GPS receiver and G-Sensor built-in. DashON provides both setting and information and also links to the Google map locations for demo applications.

You can also use the general freeware GPS viewer to set GPS setting.

Click on the “Location and Sensor”

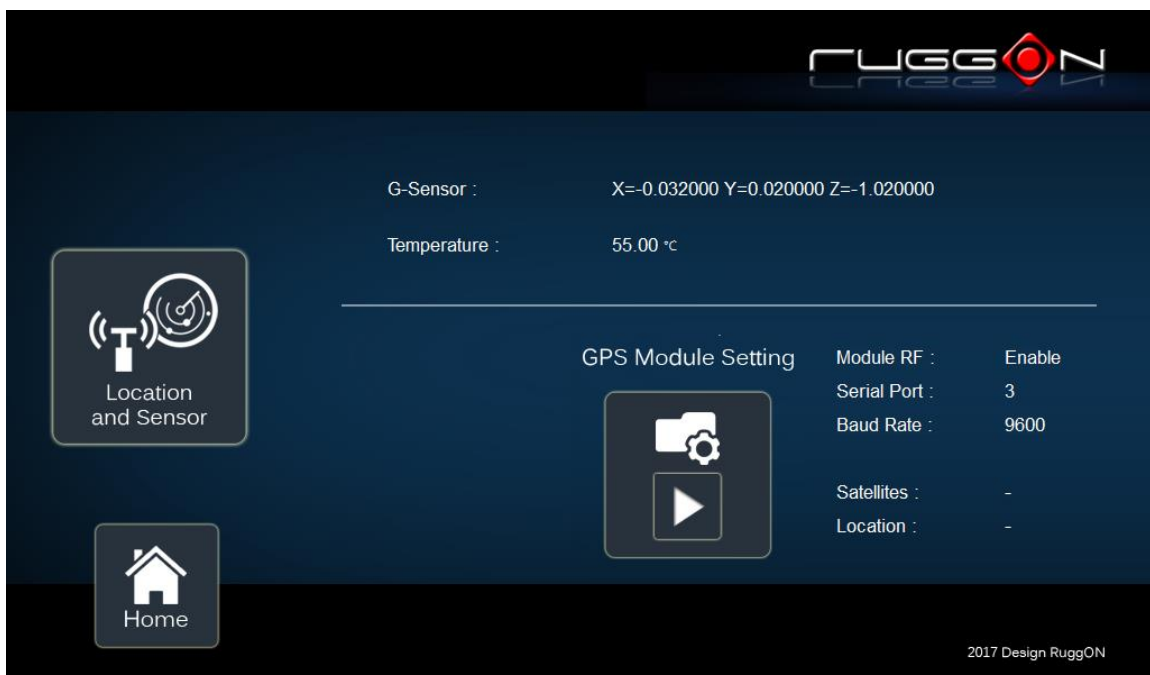

DashON includes the GPS receiver setting information; click on  to set the GPS.

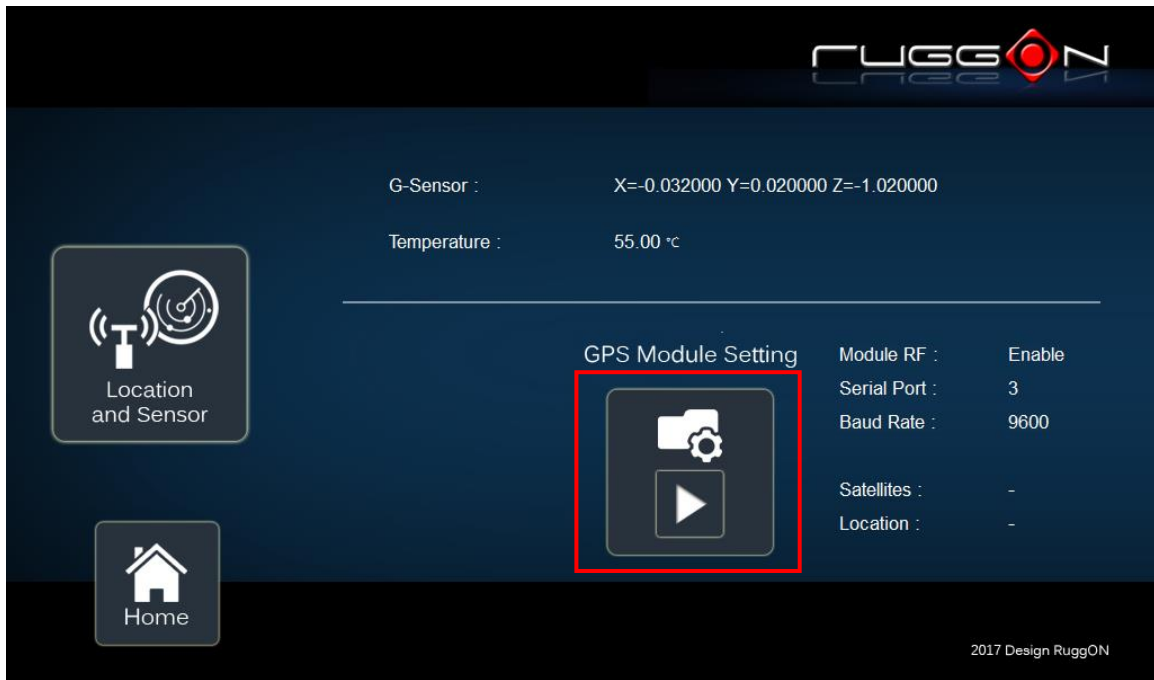

After click on , you will see the following setting screen. The following is the function description.

**Module RF:** to enable or disable the GPS receiving function.

**Serial Port Setting:** to set COM port for GPS module connected on.

**Baud Rete Setting:** to set the baud rate speed.

**Satellites:** a GPS receiver uses satellites to pinpoint locations; click here to check the receiver performance.

**Location:** to get GPS coordinates and display them in the Google Maps

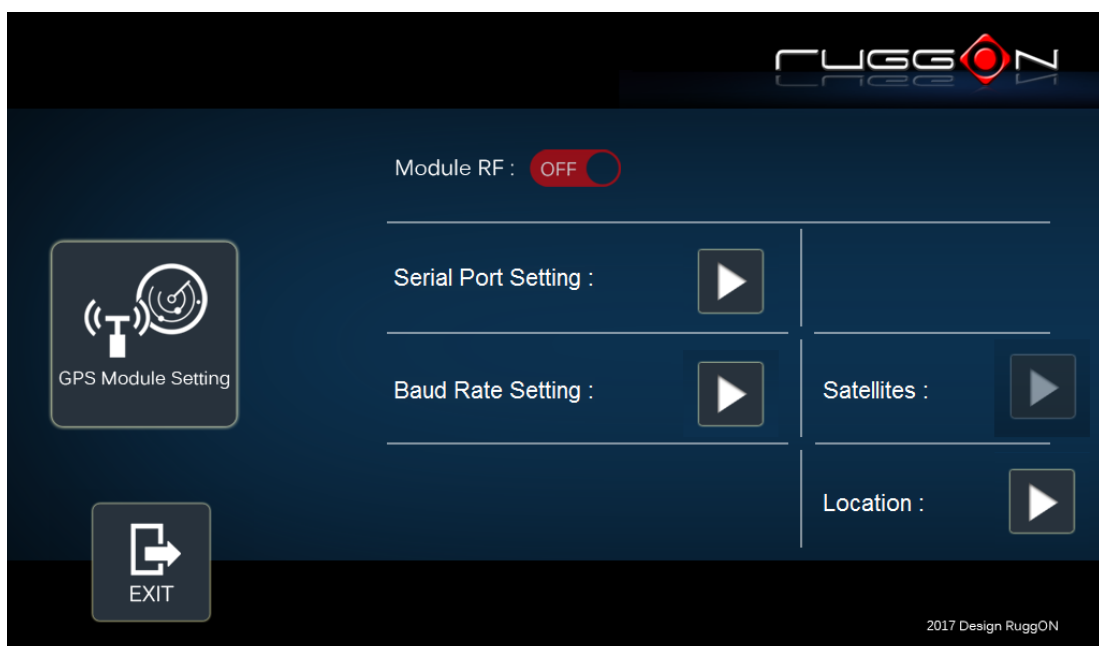

## Enable/ Disable GPS Receiver

The default GPS receiver is enabled in MT7000. If you want to disable the receiver, switch “Module RF” to .

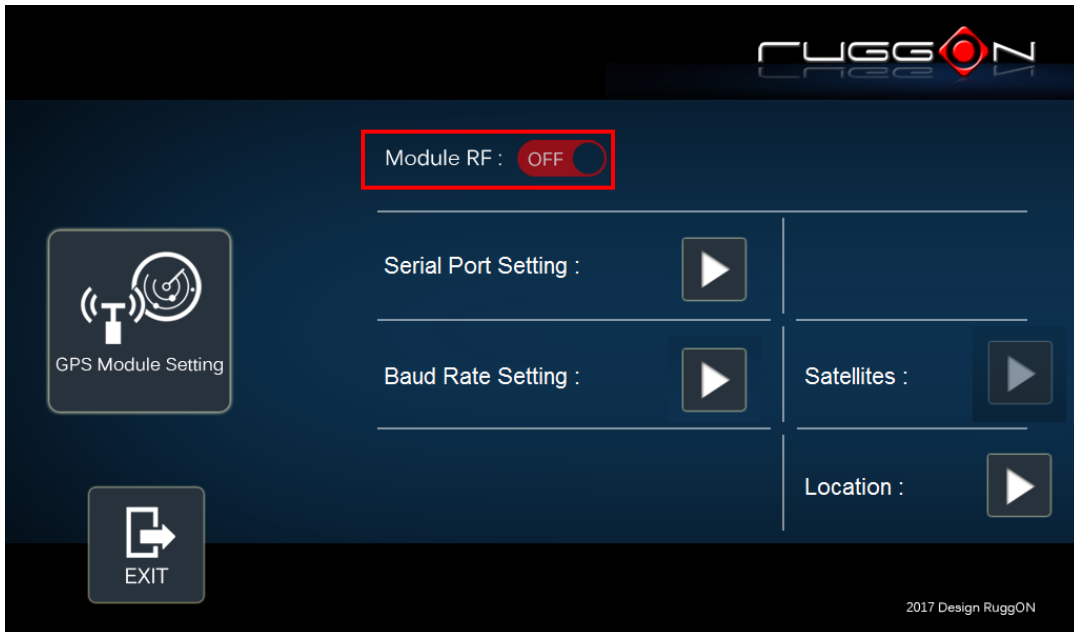

## Serial Port Setting

By selecting a COM port, you use the port from the list to connect to your GPS. MT7000 uses COM3 as its default setting for GPS receiver.

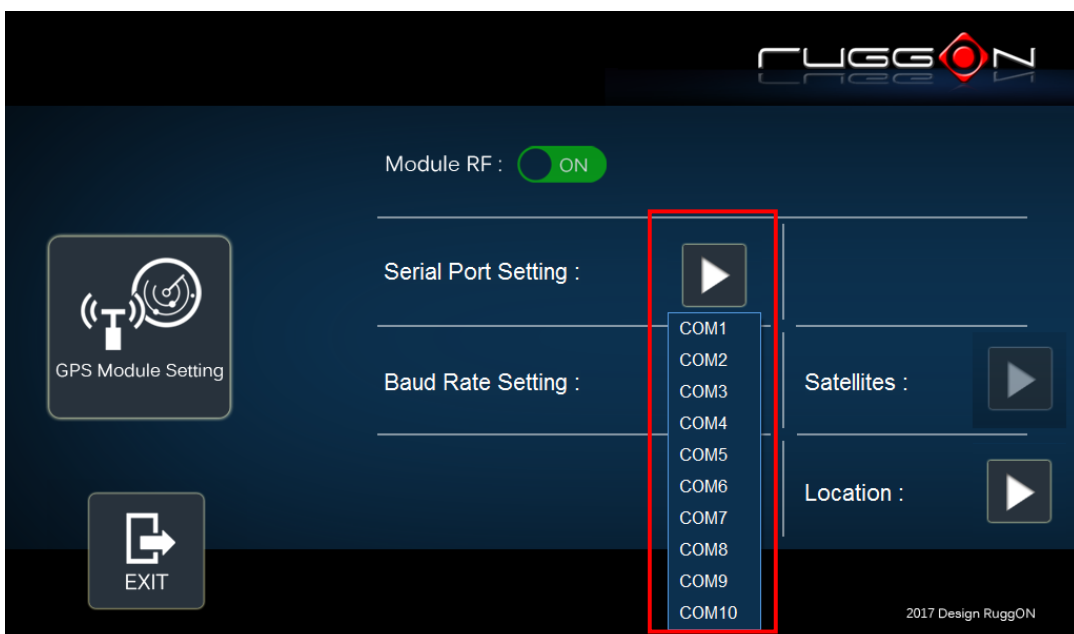



## Baud Rate Setting

It must be set to the same baud rate you are using in the GPS receiver. Use as high a Baud rate as possible. Baud Rates from 4800 to 115200 can be selected in DashON. The default is 9600.

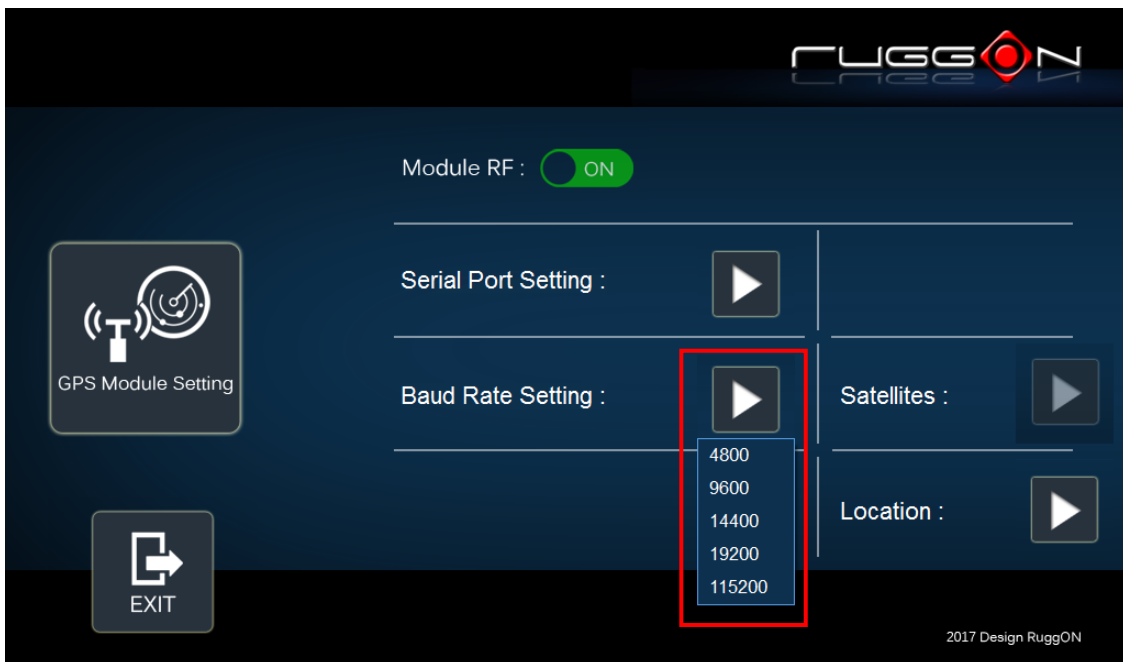

# Chapter 7. Main BIOS Setting

MT7000 is equipped with a Phoenix BIOS, which is stored in EEPROM chip.

This chapter provides information for BIOS main feature setting in hardware system.

When the system turns on, press <F2> to enter Setup.

The system displays the BIOS setup interface; you can select functions according to what you want to change.



## Set Boot Sequence

This section enables users to define and modify the boot options of bootable devices.

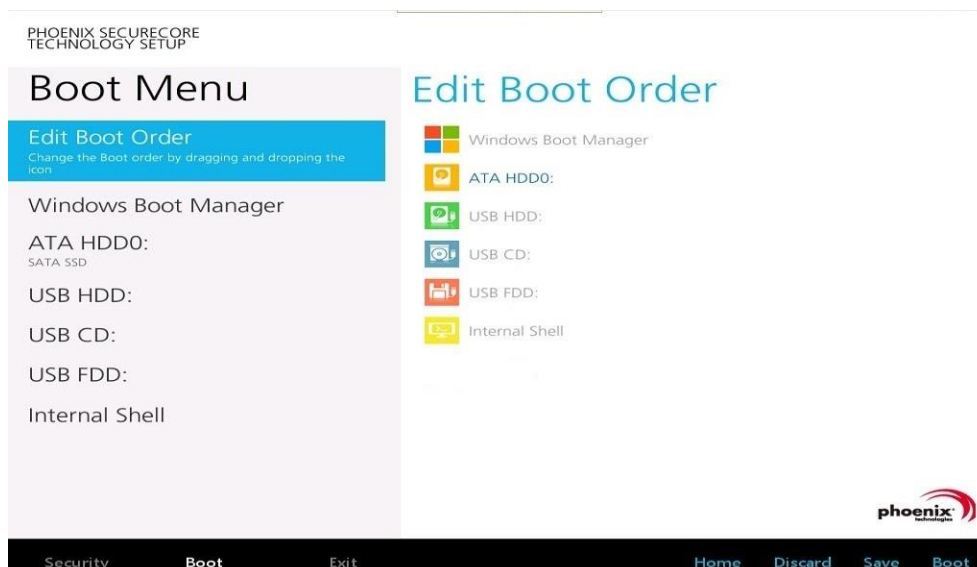

# Set the system configuration

Use the Main menu for basic system configuration; users can set the system's date, time, drive parameters, and related settings via the HDD Sub-menu.

## Setting the System Date

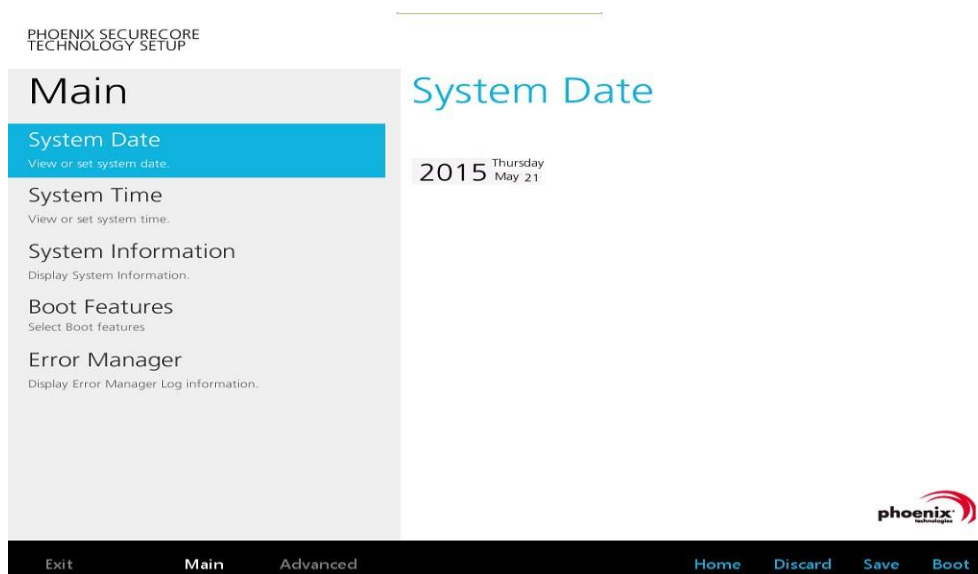

## Setting the System Time

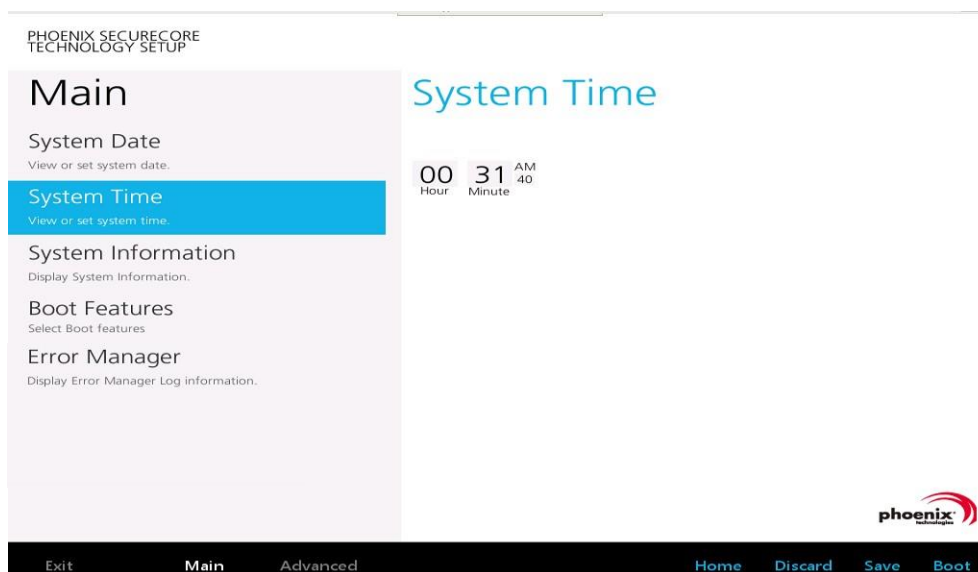

# System Information

It displays the system configuration information such as CPU, Memory size, and firmware version.

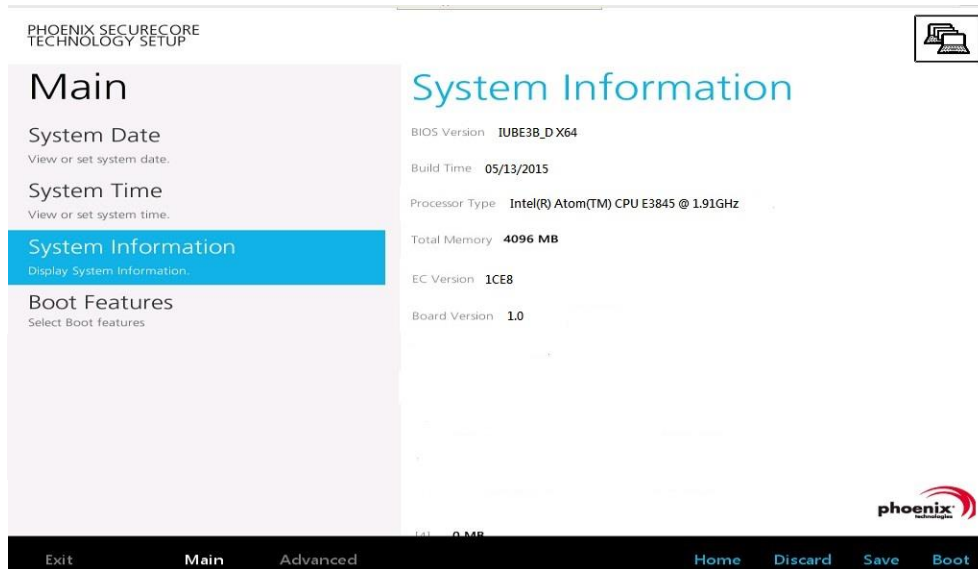

# Boot Features

Users can set the boot options for CSM support or Quick Boot. Note if the operating system is Windows 8, please set the Boot Features [Off] for “Legacy Boot”

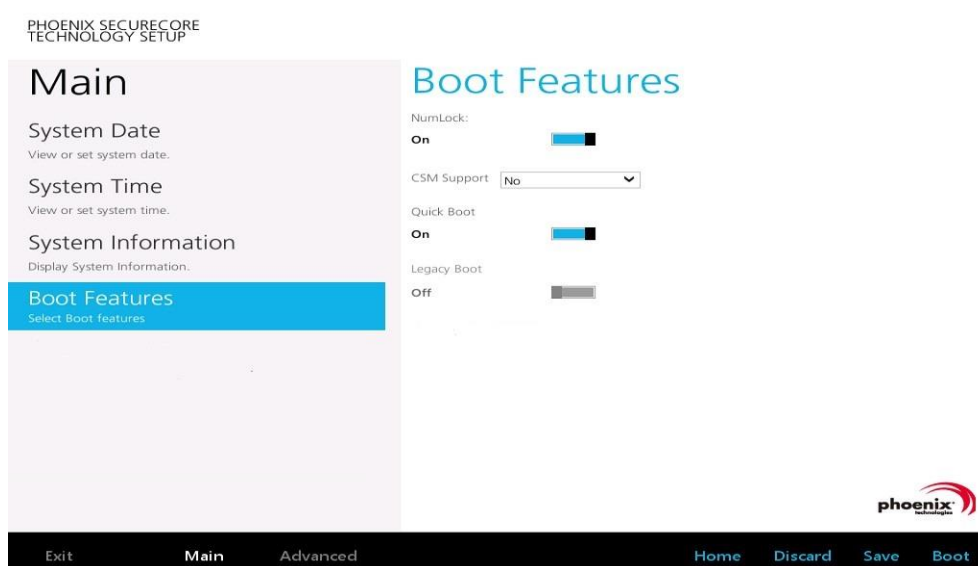

# Miscellaneous Configuration

Use Advanced menu to set the system I/O device function.

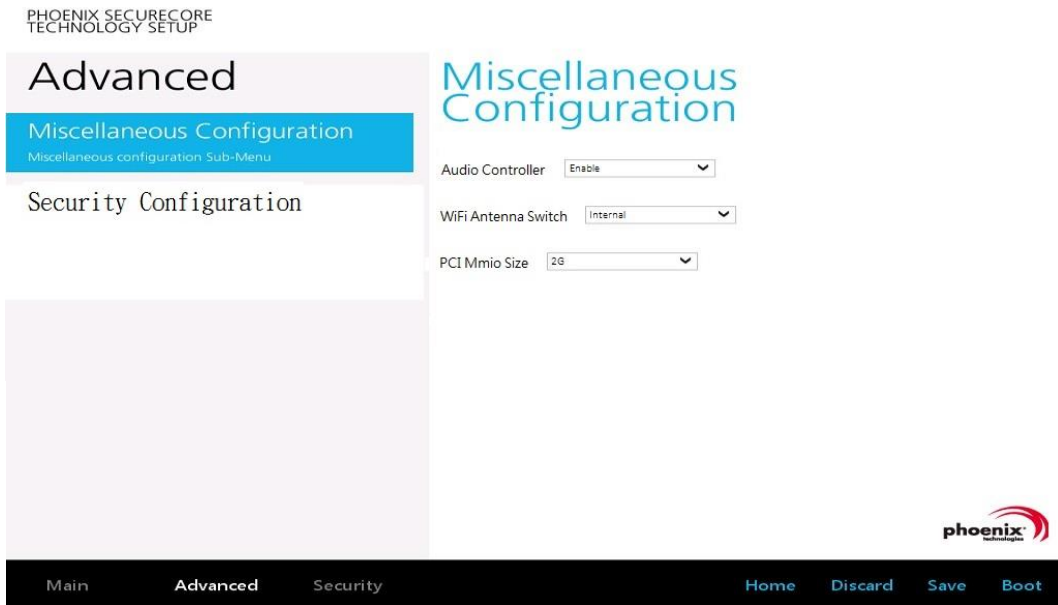

# Account's Password Setting

Use the Security Menu to establish the system password and protection for entering the BIOS or system start-up.

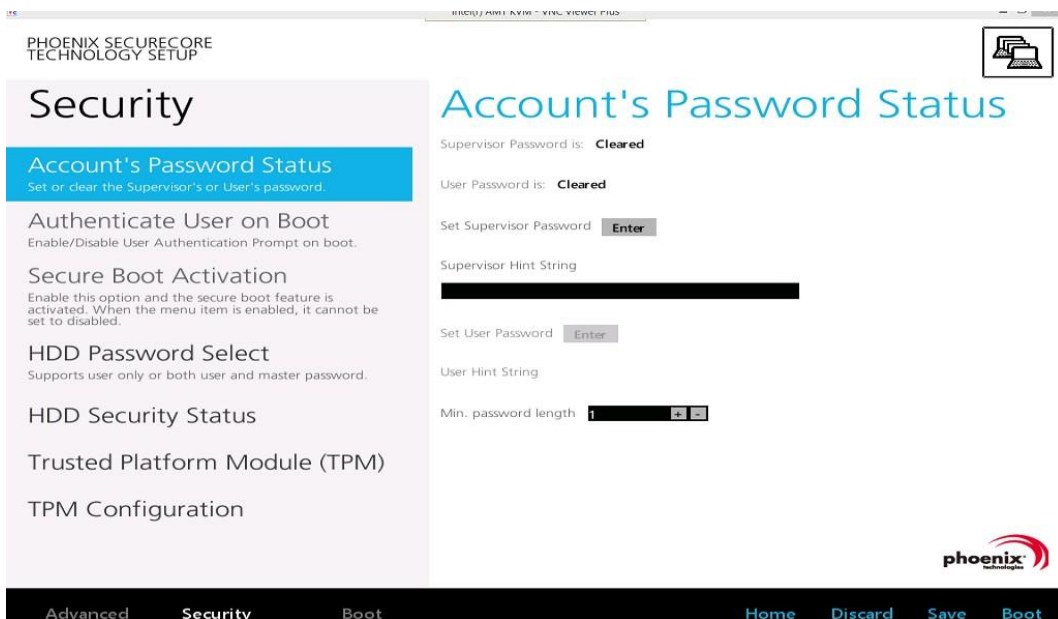

# HDD Security Setting

To establish password protection to restrict access to the contents of the hard disk drive, the HDD password is written to the system BIOS and to the hard disk drive to ensure that the password can protect your hard disk drive should it be moved to another computer.

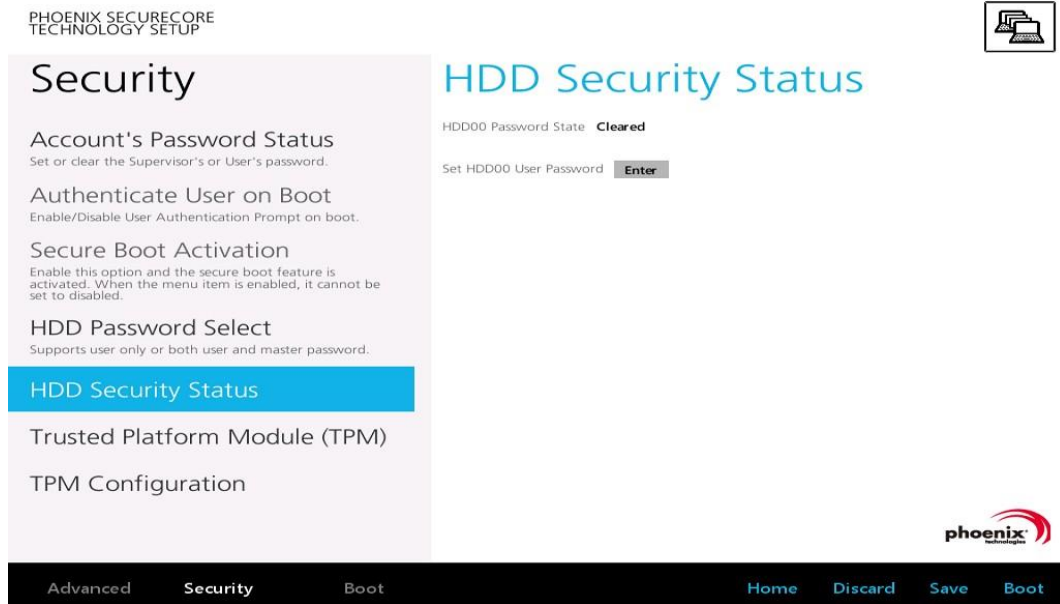

The screenshot displays the Phoenix SecureCore Technology Setup BIOS interface. The main title is "Security". The left sidebar lists several options: "Account's Password Status", "Authenticate User on Boot", "Secure Boot Activation", "HDD Password Select", "HDD Security Status" (highlighted in blue), "Trusted Platform Module (TPM)", and "TPM Configuration". The main content area is titled "HDD Security Status" and shows the following information:

- HDD00 Password State: **Cleared**
- Set HDD00 User Password: **Enter**

The Phoenix logo is visible in the bottom right corner. At the bottom of the screen, there is a navigation bar with the following options: **Advanced**, **Security**, **Boot**, **Home**, **Discard**, **Save**, and **Boot**.

# Chapter 7. Wi-Fi Hotspot Setup

MT7000 can be a gateway role for other devices to connect to the Internet. Windows has ways to create Wi-Fi hotspot, and the feature is integrated into “Network and Sharing Center”. Here is how to turn your Windows 7 into a Wi-Fi hotspot. (The process should be similar for Windows 8)

1. WWAN or LAN connection is properly connected to the Internet.
2. Make sure the Wi-Fi function is enabled (set WLAN to disabled by DashON), that isn't currently connected.
3. Go to the “Control Panel” and look for “Network and Sharing Center” and then go to “set up a new connection or network”



4. Select “Set up a wireless ad hoc (computer-to-computer) network” and click on “Next”

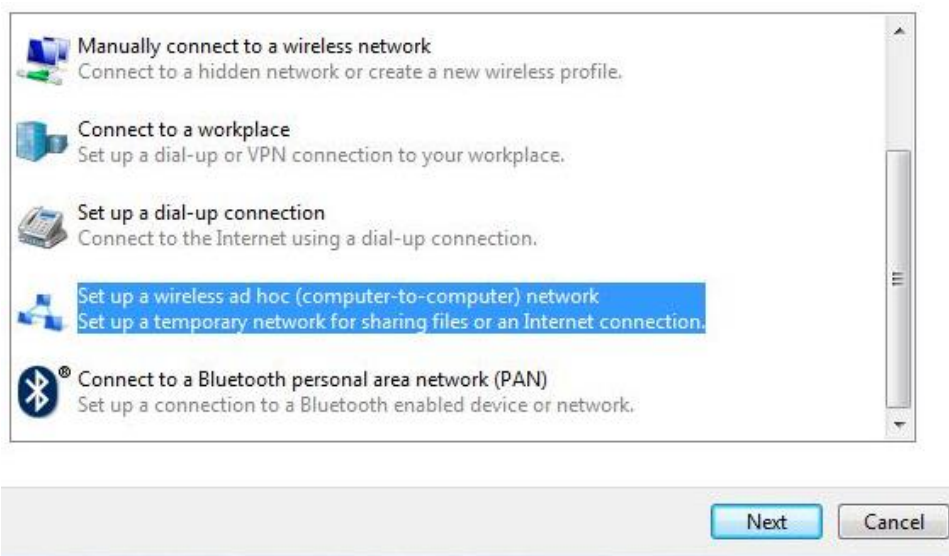

5. Click on "Next"

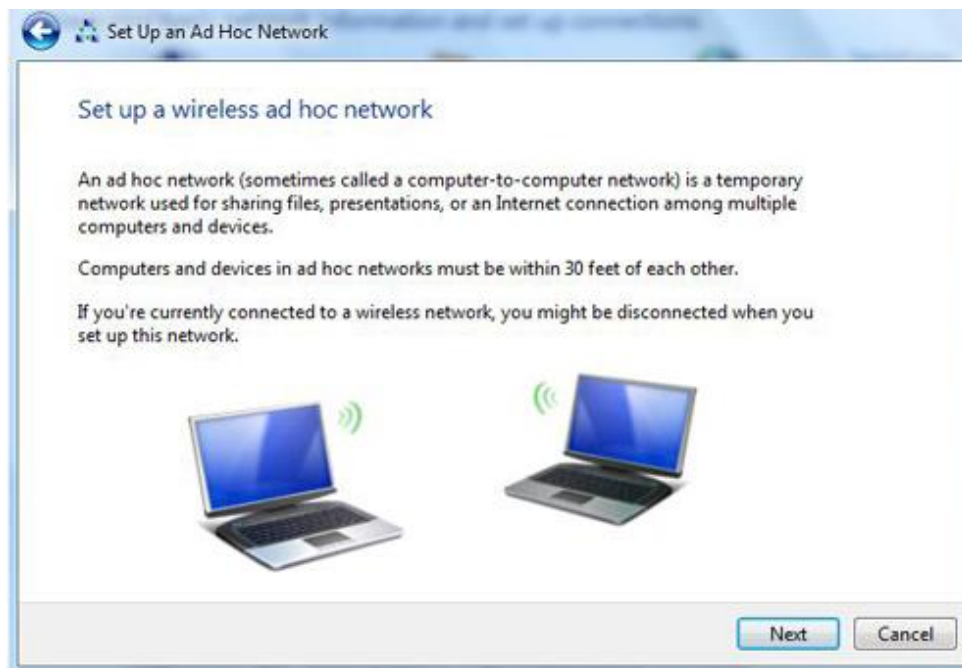

6. Enter the Network Name, choose a security type, and enter the security key. Check the "Save this network" checkbox; it will save your network name on the Wireless network connection, and then click on "Next".





7. At this point, your ad hoc network should be running and ready to start connecting your device. Click on the “Next”.



